









user manual

# DMR-IND

control panel



<b>Table of contents</b>	
<b>1- Introduction</b>	<b>4</b>
<b>2- Technical data</b>	<b>5</b>
<b>3- Description</b>	<b>6</b>
<b>4- Installation</b>	<b>8</b> 
<b>5- Connections</b>	
5.1 Power connection	9
5.2 Motor connection	10
5.3 Input connections	11
<b>6- Setting</b>	<b>12</b> 
6.1 Operating mode	12
6.2 Adjusting the transmitter activation distance	13
<b>7- Programming</b>	<b>14</b> 
7.1 Programming the dead man transmitters	14
<b>8- Verification</b>	<b>15</b> 
8.1 Verification of the installation	15
<b>9- Maintenance</b>	<b>16</b> 
9.1 Cancelling "TOTAL RESET" codes	16
<b>10- Notes</b>	<b>17</b>
<b>11- Safety instructions – Important appendix</b>	<b>18</b> 
Important installation safety instructions	18
Important handling safety instructions	19
<b>12- CE declaration of conformity</b>	<b>20</b> 

## 1. Introduction

Control unit with a built-in receiver for rolling doors and industrial facilities.

Dead Man function using wall buttons and portable transmitters. Features dead man/automatic opening mode and dead man closing mode.

The activation distance is adjustable using transmitters to ensure the door is not operated when it is not in the direct view of the user.

Complies with current standard EN 60335-1:2012



The receiver featured in this unit operates with dead man transmitters only.

### Operation

On receiving a code the equipment checks it is in the memory and activates the door opening or closing system.

- The dead man function is only activated from within the coverage area.  
If the dead man transmitter is not located in the activation area, the LED indicator will flash and you will hear 3 beeps.
- In the semi-automatic function, the open button activates the door in semi-automatic (2 minutes) mode without the user having to be within the activation area. The close button will stop the motor at any point in the opening cycle and the door can then be closed in dead man mode, provided the user is within the activation range.
- The door will stop if the dead man transmitter leaves the activation area during the closing operation.

## 2. Technical data

Characteristics of the unit	
Parameter	Value
Power	(three-phase 400Vac / 230Vac) $\pm$ 10%
Maximum motor power	Max. 1200W
Maximum consumption	0,8 A
Operating temperature	-20°C to +55°C
IP Rating	IP56
Dimensions	180 x 152 x 88 mm

Characteristics of the receiver	
Parameter	Value
Frequency	868.35MHz
Adjustable activation distance	0 - 20 m
Coding	High security changing code
Memory	27 codes, expandable to 500 codes
Number of channels	2 (open and close)

## 3. Description

- 1- **FUSE**  
315mA / 12Vdc
- 2- **OUTDOOR ANTENNA CONNECTOR**
- 3- **MEMORY EXPANSION SOCKET**  
Up-to 500 codes (memory expansion chip required)
- 4- **LED ON LIGHT**  
Power status
- 5- **OPTIONS SWITCH**  
Dead man / semi-automatic (default setting - dead man open and dead man close)
- 6- **RADIO PROGRAMMING AND RECEPTION LED LIGHT**
- 7- **DEAD MAN TRANSMITTER RANGE LIMITATION ADJUSTER**
- 8- **PROGRAMMING BUTTON**
- 9- **RECEIVER MEMORY RESET PINs**
- 10- **OPEN BUTTON**
- 11- **CLOSE BUTTON**
- 12- **BUTTON INPUTS**  
Inputs connection (Open and Close)
- 13- **STOP INPUT**
- 14- **END LIMIT INPUTS**  
End limit connection (Open and Close)
- 15- **MOTOR**  
Motor connection U (Open) V (Close) W (Common)
- 16- **THREE-PHASE OR SINGLE-PHASE POWER**
- 17- **GROUNDING**  
Grounding connection
- 18- **COVER BUTTON CONNECTION**  
Input connections (Open, Close and Stop)
- 19- **400 VAC / 230 VAC SWITCH**

## 3. Description

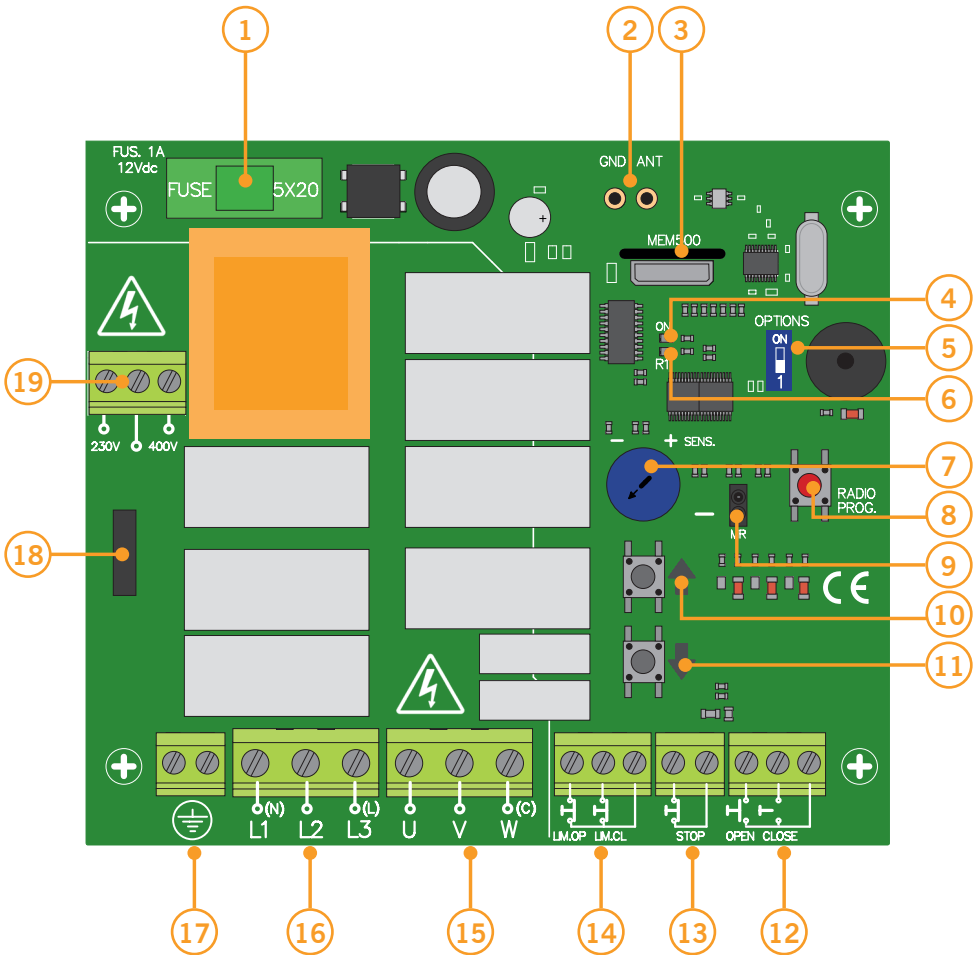

## 4. Installation



Install the control unit on the wall in a vertical position, at least 1.5 meters off the ground and in accordance with the assembly instructions.

Remove the lower side screws. Separate the box from the bracket. Use the drill template to make the holes in the wall and fix it in place using wall screws of 4 mm in diameter. Hang the box on the bracket and tighten the lower side screws.

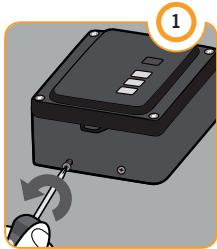

UNSCREW

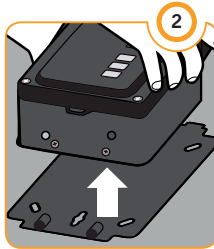

SEPARATE THE BRACKET



DRILL HOLES IN THE WALL

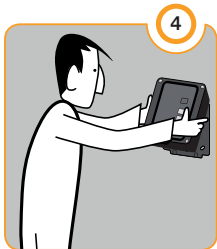

HANG THE CONTROL UNIT

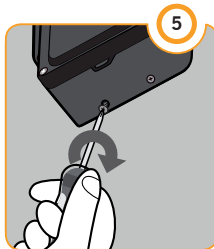

SCREW IN



## 5. Connections

### 5.1 Power connection

#### 230 V POWER

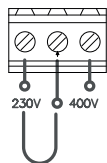

230V single-phase

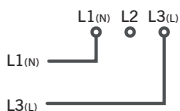

230V three-phase

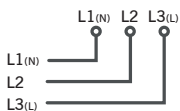

#### 400 V POWER

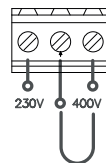

400V three-phase

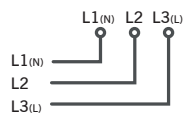

Power the equipment in accordance with the diagram above. The green ON light will remain on and the red R1 light will flash every five seconds to indicate the equipment is correctly powered.

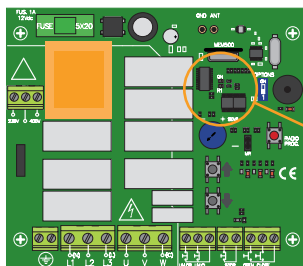

ON LED LIGHT  
RADIO PROGRAMMING AND  
RECEPTION LED LIGHT

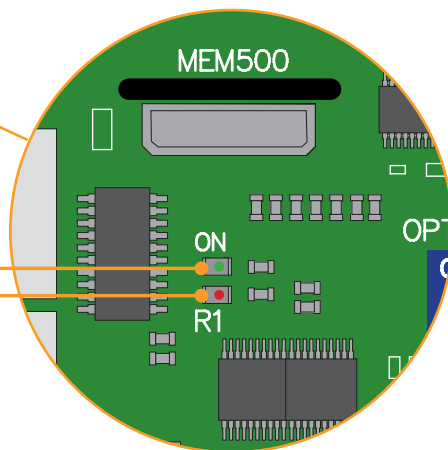

## 5- Connections

### 5.2 Motor connection

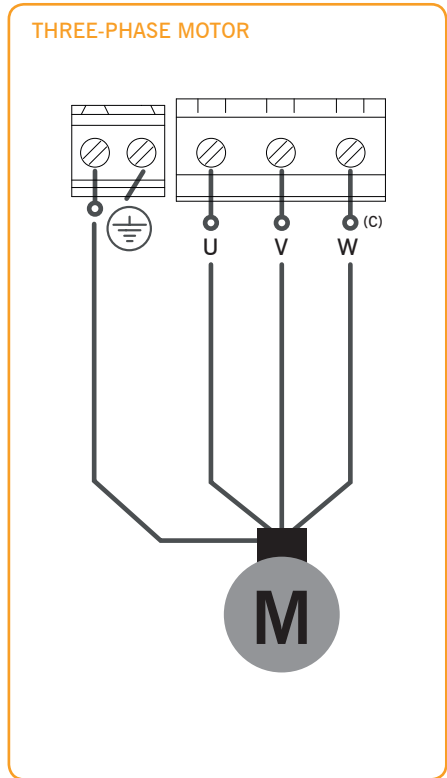
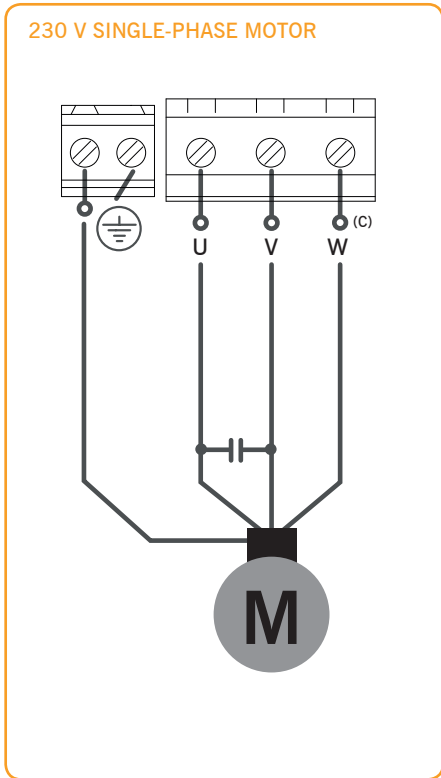

Connect the motor in accordance with the diagram above: U (open), V (close), W (common).

## 5- Connections

### 5.3 Input connections

#### INPUTS END LIMIT SWITCHES

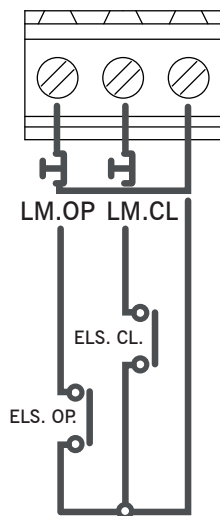

\* ELS (End Limit Switch)

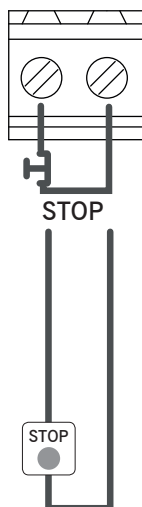

#### INPUT STOP

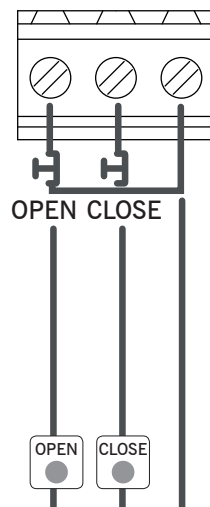

#### INPUTS OPEN-CLOSE BUTTONS



The end limit system must be connected to ensure the equipment performs correctly.  
The open and close board buttons operate in dead man mode.  
Set the option switch to OFF.

- Press the open button , the door will open until it reaches the end limit.
- Press the close button , the door will close until it reaches the end limit.



## 6. Settings

### 6.1 Operating mode

Options switch	
ON position (default option)	OFF position

Dead man function: the control unit operates in dead man mode to open and close, whenever it is activated from within the preset coverage area.

Semi-automatic function: the control unit operates in semi-automatic mode on opening (operation of a maximum of 2 minutes), with no distance limit between the transmitter and receiver, and in dead man mode on closing (whenever it is activated from within the preset coverage area.).

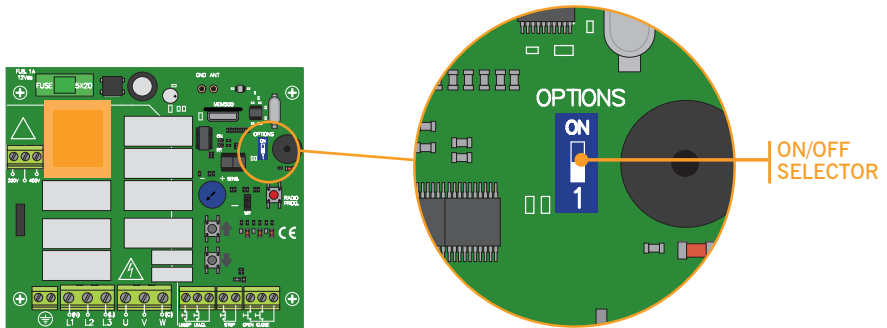

Radio programming can be opened by pressing the two first transmitter buttons of a existing transmitter during 10 seconds.

Then a new transmitter can be programmed by pressing the desired button of this new transmitter.



## 6. Settings

### 6.2 Adjusting the transmitter activation distance

The equipment is supplied with the distance activation system set the minimum. The potentiometer must be turned to the + so that the transmitters work.

Turn the potentiometer clockwise (towards the +) to increase the transmitter activation distance.

Turn the potentiometer towards the - to decrease the transmitter activation distance.

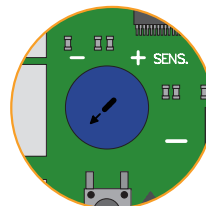

The installer is responsible for ensuring the distance selected provides the user with a direct view of the door while it is moving.

We recommend adjusting this distance when the door is closed, and then checking it can be opened and closed from both sides of the same.

If the dead man transmitter is not in the activation area, the luminous indicator will flash and you will hear three beeps. In this case you will need to increase the activation distance.



In accordance with standard EN 13241-1 and EN 12453-1 in relation to maintained pressure control devices:

- 1- "the person operating the door should have a direct view of the door, and be close to the door (a maximum of 5 meters) while it is moving, and should not be in a dangerous position"

**Any adjustment of the range of the radio beyond these recommendations compromises the installer in terms of liability in the event of material or bodily harm.**

- 2- "The release of the maintained pressure control device should stop the door before it has moved 5 cm". This implies a maximum speed of the door of 12.5 cm/s.

# 7- Programming

## 7.1 Programming the dead man transmitters

Press the "RADIO PROG" button for 1 second: the programming light will light up and you will hear a beep. Press any transmitter channel and wait for a 0.5 second beep.

Programming the transmitter in the receiver	Led R1
Pressing any transmitter channel activates the relays: 1st channel Open and 2nd channel Close, 3rd channel Open, 4th channel Close	ON

**This unit operates with dead man transmitters only.**

Each time a transmitter is programmed the equipment will emit a 0.5 second beep.

If 10 seconds passes without programming the unit or if you press the "RADIO PROG" switch, the equipment will exit the programming mode, emitting two 1 second beeps. If the equipment memory is full when programming a transmitter, the equipment will emit seven 0.5 second beeps and exit the programming mode.

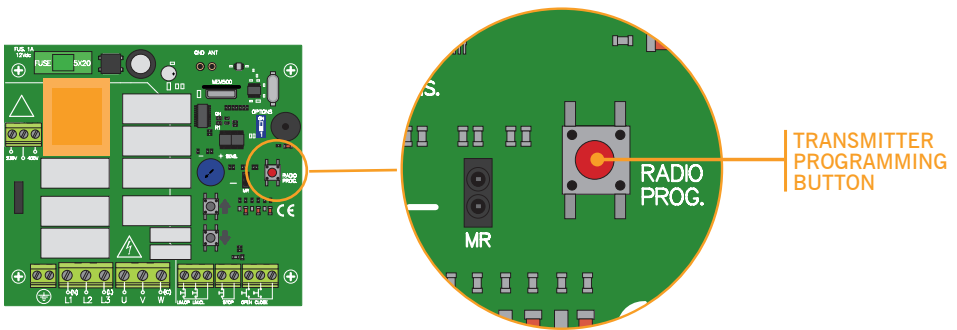

## 8- Verification

### 8.1 Verification of the installation

Conduct a full operation from both sides of the door to ensure the unit has been correctly activated in the adjusted area and that the door cannot be activated when it is not in view.

Check the motor is connected correctly, and that the semi-automatic mode operates in the open direction (and not in the close direction).



## 9- Maintenance

### 9.1 Cancelling “TOTAL RESET” codes

With the equipment in programming mode, hold down the RADIO PROG button and form a bridge in MR for over 10 seconds. The unit will emit 10 warning beeps followed by further faster beeps, indicating that the operation has been concluded. The equipment will remain in programming mode. The luminous programming indicator will follow the beeps and will flash.

If 10 seconds pass without programming the unit or pressing a switch, the equipment will exit the programming mode, emitting two 1 second beeps.

#### Luminous indicators

##### Led ON (green)

STATUS	INDICATION
On permanently	The unit is powered

##### Led R1 (red)

STATUS	INDICATION
Flashes 5 seconds	The equipment is ready to receive programmed commands
Lighting by transmitter activation	Together with three beeps means the transmitter is outside the activation area
On permanently	The receiver unit is in command programming mode

#### Sound Indicators

##### IN OPERATING MODE

STATUS	INDICATION
3 beeps	Together with lighting R1 means the transmitter is outside the activation area

##### IN PROGRAMMING MODE

STATUS	INDICATION
0.5 second beep	Control programmed
1 second beep	The equipment has entered programming mode
Two 1 second beeps	The equipment has exited programming mode
7 rapid 0.5 second beeps	The memory is full







## Important safety instructions for installation

- Disconnect the power supply before handling the equipment.
- Before installing the panel, remove all unnecessary ropes or chains and disable any equipment such as locks that is not necessary for the automatic operation.
- Before installing the panel, check that the door is in good mechanical condition, correctly balanced and that it opens and closes correctly.
- Install the manual unlocking device at a height lower than 1.8m.
- Install any permanent control next to the door away from any moving part and at a minimum height of 1.5m.
- An easily accessible disconnection device must be fitted to the wiring for permanently connected equipment. It is wise for this to be an emergency switch.
- Check that there is a security measure that protects the engine when reach the final point (open and closed).
- Check that you can not activate the door without seeing it.
- Check that the semi-automatic mode works in the open way (and not in the close way).
- This equipment can only be handled by a specialist fitter, by maintenance staff or by a suitably trained operator.
- To connect the power supply and motor wiring, 2.5 mm<sup>2</sup> section terminals must be used.
- Use protective goggles when handling the equipment.
- Fuses must only be handled when the appliance is disconnected from the mains.
- The instructions for using this equipment must remain in the possession of the user.



- European door normative EN 12453 and EN 12445 specify the following minimum protection and door safety levels: for equipment for residential, commercial and light industry use, prevent the door from being able to come into contact with any object or limit the contact force (e.g. safety edge).

### Important safety instructions for use

- Do not allow children to play with the door controls.
- Keep the remote controls out of the reach of children.
- Watch the door movement and keep people away until the door is fully open or closed.
- Precaution when operating the manual unlocking device, as the door may suddenly fall due to the bad condition of the springs or door unbalance. Details on how to use the manual unlocking device must be provided by the manufacturer or the device installer.
- Examine the installation frequently, especially the cables, springs and supports, to detect signs of wear, damage or unbalance. Do not use the door if repair work or adjustments are required, as this may cause damage.



**JCM TECHNOLOGIES, S.A.** hereby declares that the product **DMR-IND** complies with the requirements of Machinery Directive 2006/42/CE, in addition to those of Electromagnetic Compatibility Directive 2014/30/UE, Low Voltage Directive 2014/35/UE and RoHS Directive 2011/65/UE, whenever the use is consistent with that intended.

Visit our website at [www.jcm-tech.com/en/declarations](http://www.jcm-tech.com/en/declarations)

