

# RCONTACT R

## User's Manual

### Introduction

The system is designed for applications where pedestrian doors installed on garage doors. Is a position detection system of the pedestrian door status, so that if it is open the system prevents the start of the movement of the garage door. Is a wireless system composed by one transmitter and one receiver. The receiver monitors the status of transmitters connected to it.

The system complies with EN ISO 13849-1, category 2, PLC.

### Technical data

Frequency	869,50 MHz
Power supply	12/24V ac/dc (9-35V dc / 8-28V ac)
Consumption standby/operating	18mA/80mA
Memory	6 transmitters (3 on relay 1, 3 on relay 2)
Relay numbers	2 relays
Relay contacts	1A
Radiated power	< 1mW
Operating temperature	-20°C - +85°C
Seal	IP54 (with IP65 cable glands)
Box size	82 x 190 x 40mm
Range	50m

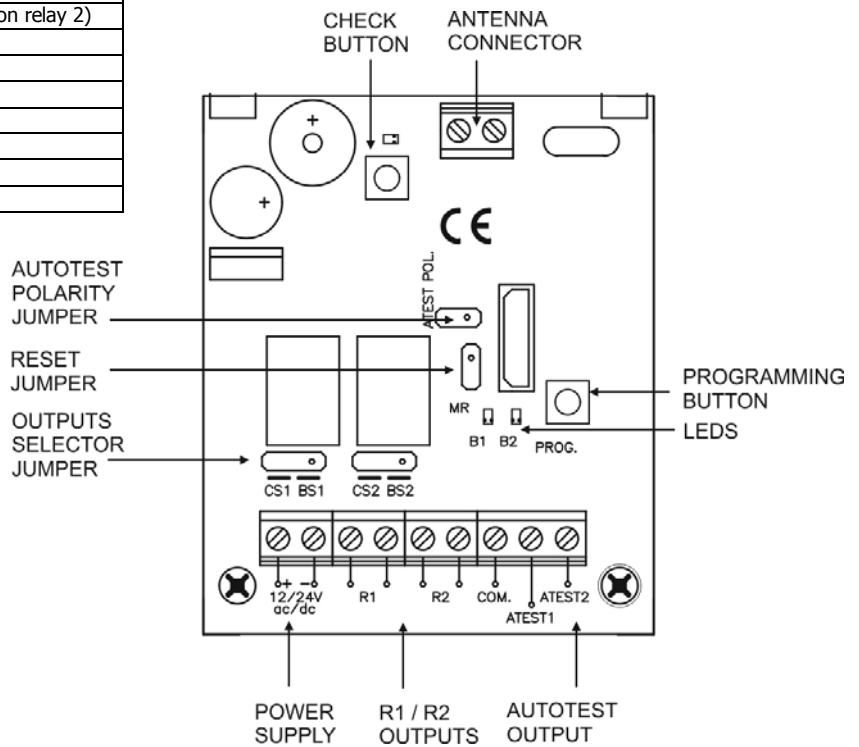

### Starting up

#### Mechanical installation

Fix the back of the box to the wall, using the wall plugs and screws supplied. Install the receiver, close to the door and avoid metal surfaces between the receiver and the transmitter. Pass the cables through the bottom of the receiver. Connect the power cables to the terminals of the printed circuit, following the indications of the connections diagram. Store the transmitter on the receiver. Fix the front of the receiver to the back with the screws supplied for the purpose.

#### Programming the transmitter on the receiver

While programming the receiver, press the PROG button on the transmitter to be programmed into the receiver. The receiver allows programming 6 transmitters (3 for Relay 1 and 3 for Relay 2). Each safety edge transmitter must be learnt into the appropriate channel of the safety edge receiver.

Mode	Configuration of transmitter programming in the receiver.	Led R1	Led R2
1	When you open the pedestrian door, relay 1 on the receiver will be activated	ON	OFF
2	When you open the pedestrian door, relay 2 on the receiver will be activated	OFF	ON
3	When you open the pedestrian door, the two relays will be activated at the same time	ON	ON

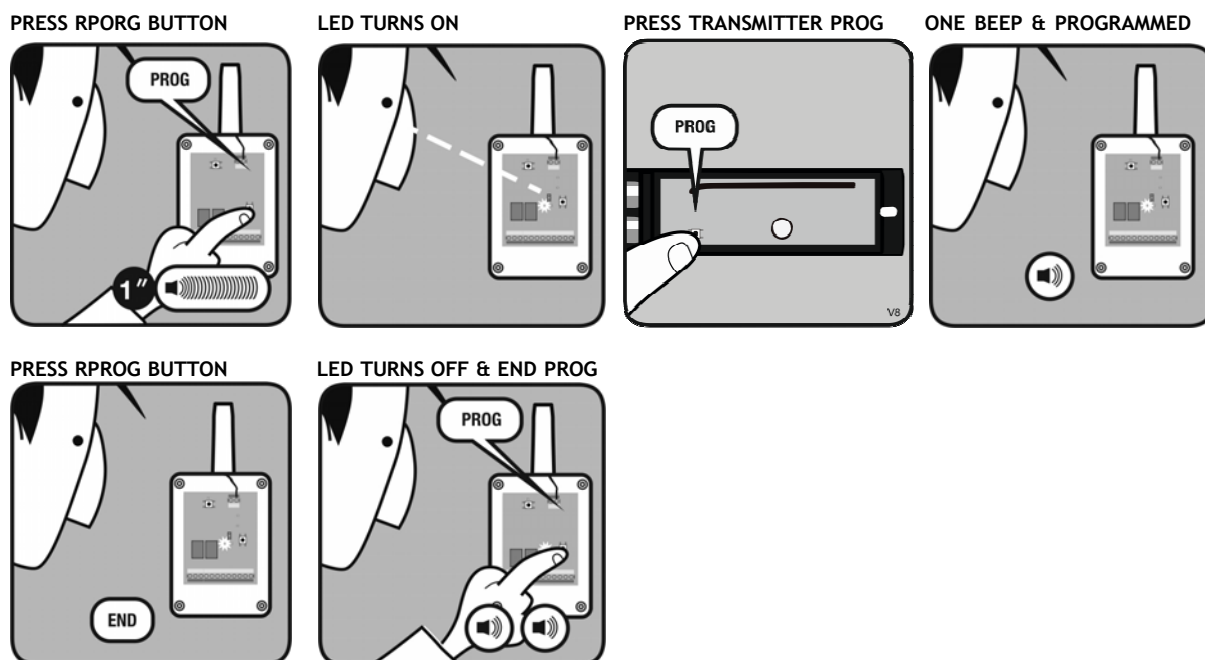

## Autotest signal

Check the autotest output on the control panel, in stanby, to see whether the voltage is 0V (positive polarization) or 12/24V ac/dc (inverted test input). Switch on the autotest signal of the panel and check that it has a maximum duration of 3 seconds.

	Autotest output in standby	Autotest output activated	Polarization type	Jumper ATEST POL	ATEST1	ATEST2
Connection to a equipment with autotest	0V	12/24V	Positive	OFF	Connected*	Connected*
	12/24V	0V	Inverted	ON	Connected*	Connected*
Connection to a equipment without autotest **	---	---	---	OFF	Not connected	Not connected

\* Nota: Connect autotest only for used outputs.

\*\* Where the autotest is not used, the system is not checked at the start of the operation, which means that security standard EN 12453 regarding the use of motorised garage doors is, in some cases, not complied with..

## Maintenance

### Beeps and leds messages / errors indication table

B1/B2 Led	Check Led	Beeps	Equipment	Message / error	Solution
ON	OFF	No beeps	RCONTACT R	Detection of pedestrian door at open state	---
				RCONTACT transmitter not programmed	Verify if it must be programmed and perform the programming.
				Communication failure between RCONTACT R and RCONTACT T	Verify the batteries of the emitter and if they are charged, verify the radio signal with the Check function.
OFF	OFF	4 beeps each 20 seconds	RCONTACT R	RCONTACT/T low battery	Verify the batteries of the transmitter
OFF	ON	No beeps	RCONTACT R	Check function. See coverage and signal quality table.	---

## System Check

This function has to be used to check the operation and range of all the devices once the installation has been carried out.

Press the receiver's **CHECK** button for at least 1 second to enter check mode. The indicator light will come on and four beeps will be heard.

Perform a complete door opening and closing manoeuvre. During the system check a beep will be heard every 1,5 seconds.

### **CORRECT OPERATION OF THE SYSTEM**

If no other acoustic signal is heard on completing the manoeuvre, the system is operating correctly. Either press the **CHECK** button again or wait 5 minutes and the receiver will exit checking automatically, indicating with two beeps that the check has been correct. The check indicator light will go out.

### **DETECTION OF TRANSMISSION FAILURE**

If the communication with a transmitter fails during checking, or the communication is deficient (for instance, too many communication retries or poor coverage), the receiver emits three consecutive beeps, indicating that an error has occurred. Halt the door manoeuvre and open the pedestrian door to detect what has failed.

- If a single beep is heard on opening the pedestrian door, this means that the safety edge is correct.
- If three consecutive beeps are heard on opening the pedestrian door, this means that the safety edge has failed.

In this event, it is recommended changing the orientation of the transmitting-receiving aerials or installing an AED-868 or FLAT-868 outdoor aerial to ensure the desired range.

On exiting check mode, seven consecutive beeps will be heard and the indicator light will flash continuously.

Perform another system check until the result is correct.

### **Signal coverage**

After opening the pedestrian door, continuous flashes, ranging from 1 to 5, indicate the signal coverage for the transmitter at the time it was detected.

Number of check LED flashes	Coverage	Result of check
1	Very weak	Safety edge failure
2	Weak	OK
3	Normal	OK
4	Good	OK
5	Very good	OK

### **Total reset**

In programming mode, keep the programming **PROG** button pressed down and make a bridge with the "MR" reset jumper for 3s. The receiver will emit 10 warning sound signals and then more at a faster frequency, indicating that the operation has been carried out. The receiver will stay in programming mode.

If 10 seconds pass without programming a transmitter, the receiver will exit the programming mode, emitting two 1 sec beeps.

### **Replacing a transmitter**

If a transmitter becomes damaged the whole system must be reset and replaced, and non-damaged transmitters must then be re-programmed into the receiver.

### **Use of the system**

This equipment is designed for applications where pedestrian doors installed on garage doors. It is not guaranteed for directly activating equipment other than that specified.

The manufacturer reserves the right to change the specification of the equipment without prior warning.

### **Important annex**

Disconnect the power supply whenever you proceed to the installation or repair of the control panel.

In accordance with the European low voltage directive, you are informed of the following requirements:

- For permanently connected equipment, an easily accessible connection device must be incorporated into the cabling.
- This system must only be installed by a qualified person that has experience with automatic doors/gates and knowledge of the relevant EU standards.
- The instructions for use of this equipment must always remain in the possession of the user.
- The frequency of the RContact system does not interfere in any way with the 868 MHz remote control systems.

