

* ALWAYS TEST THE UNIT ON SITE BEFORE INSTALLATION TO AVOID RESTOCKING FEES *

Install Preparation

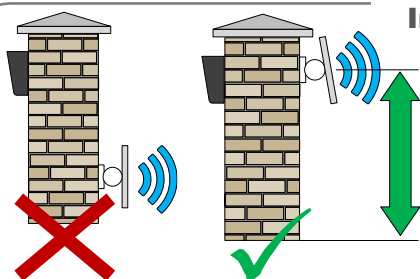

Mount the antenna as high as possible and away from obstructions such as vehicles, shrubs and trees to maximize signal strength.

Do NOT mount antenna at ground level.

Note: Do not cut or join Antenna cable.

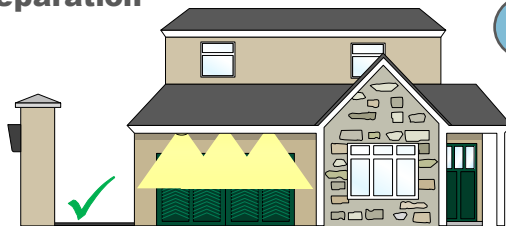

MAX DISTANCE 100m (320ft) (LAN)

This can be extended by using an ethernet cable extender (purchased separately)

1

SITE SURVEY (WiFi)



I have some WiFi signal at the gate with my phone! If not, STOP. Use LAN/CAT5 cable!



My WiFi Internet Security is WPA, WPA2, WPA3 or better.

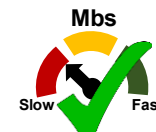

We recommend a minimum UPLOAD speed of 1.5 Mbps!

The higher the upload speed the higher the quality of your video stream will be. However, you can adjust the video stream quality should you still find it dropping frames or a little slow.

PCB

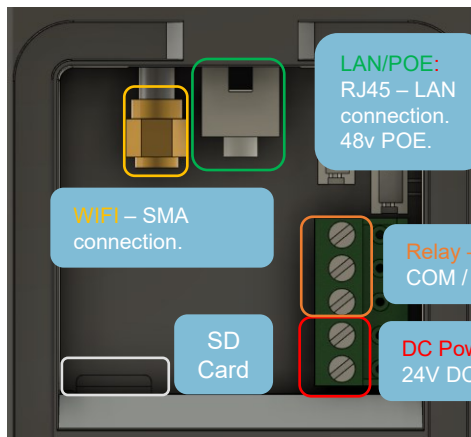

LAN/POE: RJ45 – LAN connection. 48v POE.

WiFi – SMA connection.

SD Card

Relay – NO / COM / NC

DC Power – 24V DC 2 AMP

2

Site Wiring



Note: Up to 50m using 2.4GHz with an average home router and clear line of sight.

Further distances can be achieved with advanced additional equipment.

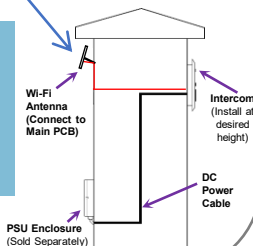

3

POWER CABLE

KEEP POWER SUPPLY AS CLOSE AS POSSIBLE.

TIP: Most technical calls received are due to installers using CAT5 or alarm cable to power the unit.

NEITHER are rated to carry enough power! (1.2amp peak)

Please use the following cable:

- Up to 2 metres (6 feet) – Use minimum 0.5mm² (18 gauge)
- Up to 4 metres (12 feet) – Use minimum 0.75mm² (16 gauge)
- Up to 8 metres (24 feet) – Use minimum 1.0mm² (14 gauge)

Power Consumption: Standby = 170mA Max = 300mA

INGRESS PROTECTION



We recommend sealing all entry holes for prevention of insects that can cause issues with a risk of shorting out components.



To maintain the IP54 rating please follow the sealing instructions included. (also available online)



LIGHTNING PRONE AREAS MUST USE SURGE PROTECTION FOR POWER SUPPLY!

Relay

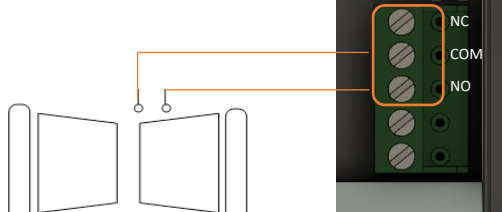

Power

Power In – 24V DC 2 AMP – use supply provided for power

24V AC-DC 2 AMP

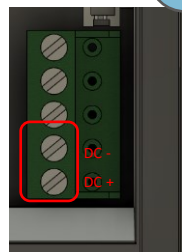

4



EXTRA RESOURCES

NEED MORE ASSISTANCE?

+44 (0)288 639 0693

SCAN THIS QR CODE TO BE BROUGHT TO OUR RESOURCES PAGE. VIDEOS | HOW-TO GUIDES | MANUALS | QUICK START GUIDES

* ALWAYS TEST THE UNIT ON SITE BEFORE INSTALLATION TO AVOID RESTOCKING FEES *

Install

POWER CABLE

KEEP POWER SUPPLY AS CLOSE AS POSSIBLE.

TIP: Most technical calls received are due to installers using CAT5 or alarm cable to power the unit.

NEITHER are rated to carry enough power! (1.2amp peak)

Please use the following cable:

- Up to 2 metres (6 feet) – Use minimum 0.5mm² (18 gauge)
- Up to 4 metres (12 feet) – Use minimum 0.75mm² (16 gauge)
- Up to 8 metres (24 feet) – Use minimum 1.0mm² (14 gauge)

EARTHING & INGRESS

This product **MUST** be EARTHED in the following states in order to qualify for manufacturers warranty

- FL, LA, MS, AR, OK, MO, AL, IL, KY, TN, IN, KS, SC, GA, IA, TX, OH, NC, NE, MD, WV, VA, DE



We recommend sealing all entry holes for prevention of insects that can cause issues with a risk of shorting out components.



To maintain the IP54 rating please follow the sealing instructions included. (also available online)

Relay 2 and exit button

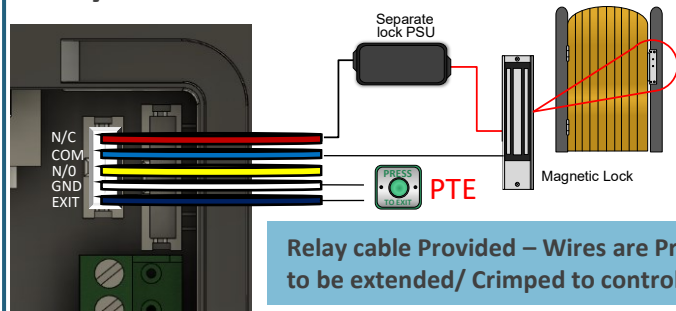

Relay cable Provided – Wires are Pre-cut to be extended/ Crimped to controller



EXTRA RESOURCES

NEED MORE ASSISTANCE?

+44 (0)288 639 0693

SCAN THIS QR CODE TO BE BROUGHT TO OUR RESOURCES PAGE.
VIDEOS | HOW-TO GUIDES | MANUALS | QUICK START GUIDES

* ALWAYS TEST THE UNIT ON SITE BEFORE INSTALLATION TO AVOID RESTOCKING FEES *

1 Download the programming/user app. 'AES OPYN'

Add Intercom to Device (LAN)



Note: Slight differences will be seen between the Android and iOS app versions, any major differences will be highlighted in the screenshots below.



App download

1 Open App and add a device

2 Select "Search LAN"

3 Select your device

4 Enter device password

System is ready when you can hear a double beep



Tip: The device UID and password can both be found on the back of device along with the QR code

5 If LAN connection works you should see this page. Click "Add".

6 Follow the steps provided by the app, such as naming the device and setting the admin password. Afterwards device should appear online like this.

Tip: If admin password is lost/forgotten only way to reset is to default the system.

Add Keypad or QR Code *The process for creating Keypad or QR codes is the same

1 Click the device settings icon from the app home screen and select "Settings".

2 Select "Unlock Settings"

3 Select Keypad or QR Codes

4 Click the "+" icon

5 Select name and relay

6 Select desired number of uses

7 Select duration of validity

Tip: Toggling on the "Unlimited" uses and "Forever" validity will make the code permanent (24/7)

* ALWAYS TEST THE UNIT ON SITE BEFORE INSTALLATION TO AVOID RESTOCKING FEES *

1 Download the programming/user app. 'AES OPYN'

Note: Slight differences will be seen between the Android and iOS app versions, any major differences will be highlighted in the screenshots below.

Add Intercom to Device Wifi (Antenna Sold Separately)

App download

If first time install or after a factory reset, device will create a local network on boot-up used later in the setup.

1

2

System is ready when you can hear a double beep

Open App and add a device

Tip: Existing installs may also create this local network if needed by typing *1920# into the keypad

3

Scan the device QR code

Tip: The QR code can be found on the back of the device.

4

Ensure local network is active

Successful reset

5

Select desired network and enter details

6

Wait for system to bind and connect

7

Follow the steps provided by the app, such as naming the device and setting the admin password.

Afterwards device should appear online like this.

Tip: If admin password is lost/forgotten only way to reset is to default the system.

* ALWAYS TEST THE UNIT ON SITE BEFORE INSTALLATION TO AVOID RESTOCKING FEES *

Download the programming/user app. 'AES OPYN'



Note: Slight differences will be seen between the Android and iOS app versions, any major differences will be highlighted in the screenshots below.



App download

Test Keypad Code

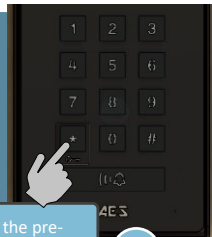

- 1 Enter the pre-programmed code
- 2 Press the * button to confirm code

Hold Open Relay

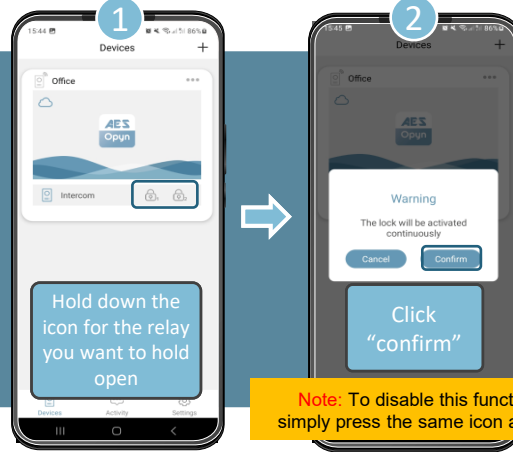

Note: To disable this function simply press the same icon again.

Change Unlock Duration

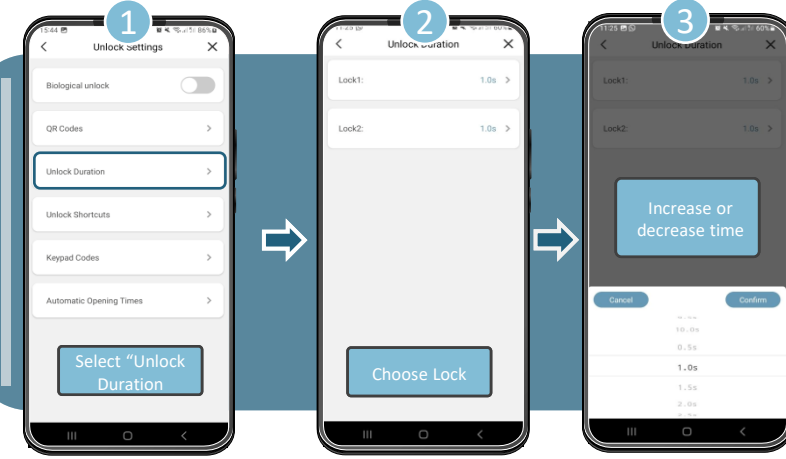

Additional Android Settings

Note: Call may appear in one of two ways depending on phone type, software version, settings and more.

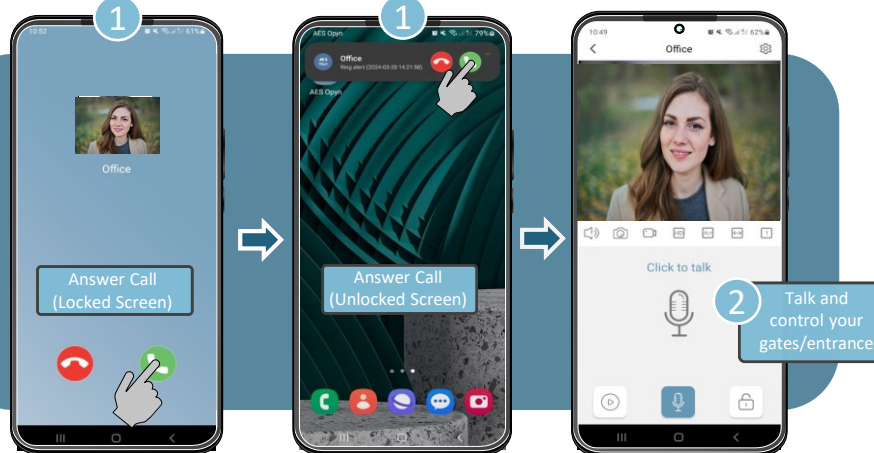

Answering on iOS (Apple)

Note: Call may appear in one of two ways depending on phone type, software version, settings and more.

Note: Various versions of iOS and Android OS will have different notification acceptance techniques. Please refer to online support for your device if needed.



* ALWAYS TEST THE UNIT ON SITE BEFORE INSTALLATION TO AVOID RESTOCKING FEES *



Note: Slight differences will be seen between the Android and iOS app versions, any major differences will be highlighted in the screenshots below.



App download

Sharing Device – Search Account

- Click the device settings icon from the app home screen and select the "Share" option.
- Click the "+" icon
- Enter details of device, but this time use the new "Username" and "Password"
- If the account is found, you can choose to share your device

Note: After sharing the user will have to accept on their app

INTERCOM MAINTENANCE

Bug ingress is a common issue in unit failures. Ensure that all components are sealed accordingly and check occasionally. (Do not open the panel in the rain / snow unless correctly equipped to keep the internals dry. Ensure the unit is securely closed after maintenance)

ENVIRONMENTAL INFORMATION

The equipment that you bought has required the extraction and use of natural resources for its production. It may contain hazardous substances for the environment. In order to avoid the dissemination of those substances in our environment and to diminish the pressure on the natural resources, we encourage you to use the appropriate take-back systems. Those systems will reuse or recycle most of the materials of your end-of-life equipment.

The crossed-bin symbol marked in your device invites you to use those systems.



If you need more information on the collection, reuse and recycling systems, please contact your local or regional waste administration. You can also contact AES Global Ltd for more information on the environmental performances of our products.

Sharing Device – QR Code

- Click the device settings icon from the app home screen and select the "Share" option.
- Click the "+" icon
- Click more ways to share
- Let the other user scan the QR code with their app or share the QR with them using the link option.

WARRANTY

Please note, by installing this product, you are accepting the following warranty terms:

- The manufacturer's warranty is a "return to base" 2-year warranty from date of manufacture. This means that any suspected defective components or items are returned to the manufacturer's agent for investigation and diagnosis and returned at the cost of the customer.
- The warranty does not cover, nor is the manufacturer or agent responsible for any of the following whatsoever: Storm damage, lightning or surge damage, flooding, accidental damage, vandalism or deliberate damage, unexplained corrosion or unusually harsh environments, failure of telephone networks, future un-interoperability between the product and network providers which cause malfunction due to changes implemented by the phone providers after manufacture of the product, or that which is outside of control of the manufacturer (e.g. 2G, 3G switch off, removal or inability to obtain VOLTE service), and damage due to not proper installation.
- The manufacturer in no way accepts liability for any of the following incurred due to a product defect: Cost of attending site, inconveniences, labour rates, time lost, loss to or damage to property, security breaches, late payment clauses or breaches of any contracts between the installer and the client.
- This is a profession install product only. The product is a component of an overall system. Therefore, it is the responsibility of the installer to certify the safety and compliance of the overall finished system. As soon as this product is fixed to another item, or connected to another third-party device, then the product has been modified, and compliance with local regulations in the country of install is strictly the responsibility of the installer.
- Re-stocking fees may apply to items returned that are found to be non-defective. Complete units will also attract a re-stocking fee if returned for credit, regardless if a defect is discovered or not. Re-stocking fees may vary depending on the condition of the item being returned, and whether it can be determined as in brand new condition. The warranty terms do not entitle customers to an automatic full refund. For more details on returns procedures and re-stocking fees, contact the agent.
- Items with physical signs of surge damage are not covered by warranty. Items with visible signs of surge damage will only be covered by warranty if photographic evidence is provided from site, showing surge protection has been installed.

Full warranty terms and conditions available upon request to AES Technical Department.

* ALWAYS TEST THE UNIT ON SITE BEFORE INSTALLATION TO AVOID RESTOCKING FEES *

Alexa & Google Integration Instructions

• Alexa



1. Download the “AES Opyn” app via Google Play or App Store.
2. Launch the app and register an account (or login if you have already registered)
3. Connect and set up your AES Opyn device(s) via the app.
4. Search for the “AES Opyn” skill in the “Amazon Alexa” app skill directory.
5. Click “Enable” and proceed to link your AES Opyn and Amazon account.
6. Once successfully linked you can add your device(s) using the “discover devices” option on the Alexa app.
7. After adding the device(s) you can rename them to your liking and start using the voice control commands.

• Google



1. Download the “AES Opyn” app via Google Play or App Store.
2. Launch the app and register an account (or login if you have already registered)
3. Connect and set up your AES Opyn device(s) via the app.
4. Search for the AES Opyn service in the “Google Home”, home control service directory.
5. Connect/Link your AES Opyn and Google Home accounts.
6. The Opyn devices you had connected to your “Opyn” app should then automatically appear in your Google Home app.



EXTRA RESOURCES

NEED MORE ASSISTANCE?

+44 (0)288 639 0693

SCAN THIS QR CODE TO BE BROUGHT TO OUR RESOURCES PAGE.

VIDEOS | HOW-TO GUIDES | MANUALS | QUICK START GUIDES

* ALWAYS TEST THE UNIT ON SITE BEFORE INSTALLATION TO AVOID RESTOCKING FEES *

Reset / Default Device

If you need to default the system back to factory settings this can be done by entering the reset code sequence into the keypad.

Default Sequence: *1590#

(Note: This code can be changed)

Unbind Device

If you wish to clear the device of all users and do not have access to their app you can delete them manually by entering the unbind code sequence into the keypad.

Default Sequence: *1910#

(Note: This will remove admin and all shared users)

Change “Reset Code”

If you wish to change the reset code from its default value this can be done entering the following sequence into the keypad

Sequence: Sequence: XXXX#CODE# (XXXX = Current Code, CODE = New Code)

(Note: If you lose or forget this code a master reset on the system will be needed)

Create Local Network

If you need to configure WIFI again due to changing router or network password, but device is already “offline” then use this sequence to create local network used in setup.

Sequence: *1920#

(Note: This will not remove any programming)

Master Reset

Press tamper alarm button 5 times within 3 seconds



If you need to default the system and do not know the reset code due to it being changed from its default value, you can use this process to fully reset the system.

Note: Performing this process will remove all current programming including saved users & access codes.



Manufacturer: Advanced Electronic Solutions Global Ltd
Address: Unit 4C, Kilcronagh Business Park, Cookstown, Co Tyrone, BT809HJ, United Kingdom

FCC ID: 2ALPX-OPYNIPIBK

Grantee: Advanced Electronic Solutions Global Ltd

Complies with the following essential requirements for 2014/53/EU:
EN 301 489-1 V2.2.0 (2017-03) (Electro-Magnetic compliance)
EN 301 489-17 V3.2.0 (2017-03) (Electro-Magnetic compliance)
EN 62479:2010 (Maximum output power)
EN60950-1:2006+A11:2009+A1:2010+A12:2011+A2:2013 (Electrical Safety)

This device complies with Part 15 of FCC rules. Operation is subject to the following two conditions: (1) this device may not cause harmful interference, and (2) this device must accept any interference received, including interference that may cause undesired operation.

Notified body: Shenzhen HUAK Testing Technology Co., Ltd.
CNAS Number: L9589
This declaration is issued under the sole responsibility of the manufacturer.

Output power listed is conducted. This device must be installed to provide a separation distance of at least 20 cm from all persons and must not be co-located or operating in conjunction with any other antenna or transmitter.

Signed by:

RF Exposure Statement

To maintain compliance with FCC's RF Exposure guidelines, This equipment should be installed and operated with minimum distance of 20cm the radiator your body. This device and its antenna(s) must not be co-located or operation in conjunction with any other antenna or transmitter

Paul Creighton, Managing Director.
Date: 18th July 2024



STILL HAVING TROUBLE?

Find all of our support options such as Web Chat, Full Manuals, Customer Helpline and more on our website:

WWW.AESGLOBALONLINE.COM

+44 (0)288 639 0693