



C Prox Ltd (inc Quantek)

Unit 11 Callywhite Business Park, Callywhite Lane, Dronfield, S18 2XP
+44(0)1246 417113 sales@cproxltd.com www.quantek.co.uk

RX-4 Instructions

The RX-4 is designed to work with all wireless C Prox touch sensors, handheld and desk mount remotes.

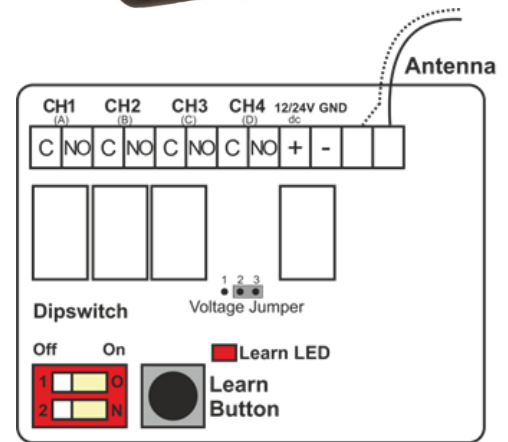

Specification:

- 12/24Vdc
- 868MHz
- 4 channel
- 1A 24Vdc normally open contacts
- Momentary/bi-stable selectable relays
- 200 code memory
- Dimensions: 65 x 50 x 30 mm

Voltage jumper	
24V	Pins 2&3 bridged
12V	Pins 1&2 bridged

Installation:

1. The receiver is designed for internal use only. If used externally it needs to be housed in a waterproof enclosure.
2. Before making any connections ensure that power to the equipment you are connecting to is switched off.
3. Remove cover and connect 12/24Vdc to the marked terminals, ensure polarity is correct way round, and the voltage jumper is in the correct place.
4. Wire relay outputs to the equipment as required.
5. Switch on power.
6. Conduct programming procedure as per below.
7. Set dip-switches appropriately and replace cover.
8. Do not cut the single white antenna wire. For maximum performance keep away from mains cables.

Dipswitch settings		
	ON	OFF
1	CH1&2 – Bi-Stable	CH1&2 – Momentary
2	CH3&4 – Bi-Stable	CH3&4 – Momentary

Touch sensor programming:

1. Press and release the learn button, the learn LED will light up for 10 seconds.
2. During this time, activate the touch sensor. The learn LED will flash to confirm programming.
3. Standard touch sensors program onto channel 1.

Remote transmitter programming:

1. Press and release the learn button, the learn LED will light up for 10 seconds.
2. During this time, press the transmitter button you wish to program. The learn LED will flash to confirm.
3. Repeat for additional buttons and transmitters if required.

Deleting the memory:

To delete the memory press and hold the learn button for approximately 10 seconds until the LED flashes and turns off. All the transmitters have now been removed from the memory.

