



SQUARE & SINGLE GANG Manual

Proximity switch for activation and access control

Hard coated, scratch resistant, anti-reflective, anti-microbial Steritouch acrylic label

Entire label is sensitive

www.quantek.co.uk 01246 417113



Installation:

Ascertain fixing height. Use the box to mark the four fixing points.

Use knockout and place cable through if hardwiring.

Fit seal to back of box if being used externally (Square only), and secure box to the wall with 4 x No8 (4mm) screws.

Make connections (see below, do not leave excessive cable in the back box), or connect battery clip and place battery holder in the marked compartment, then program into the receiver (see next page)

Place signage plate back into the box and insert the two screws.

Do not over tighten screws!

Hardwired specification:

12 – 28Vdc

8mA (standby) / 35mA (max)

+18mA LEDs

Sensitivity – Touch - up to 70mm

Selectable red, green, blue LEDs

Sounder on activation

Timer 1 - 27 seconds

Latching function

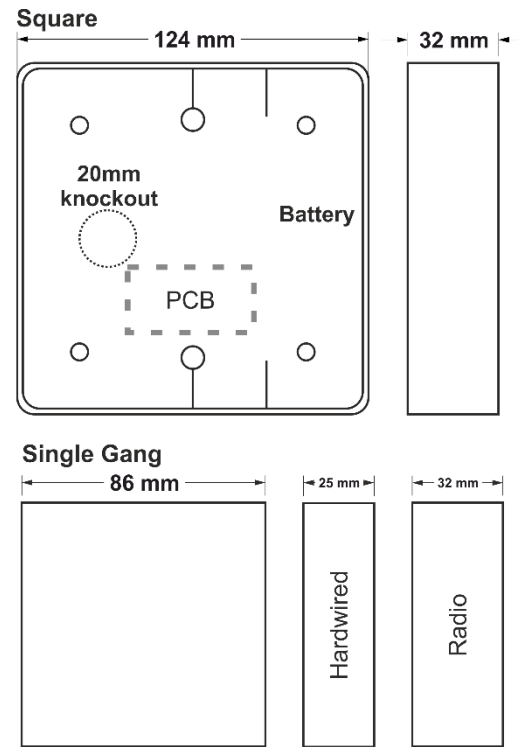
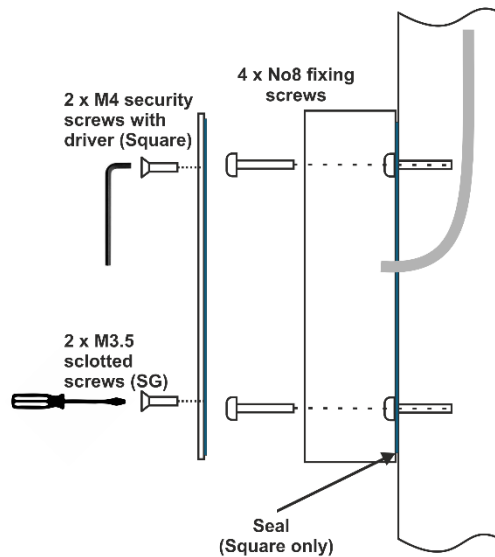

Wiring diagrams

Hardwired sensor wiring. Alter LED colour configuration as required.

Normally open contacts. 0v switching (Most operators)

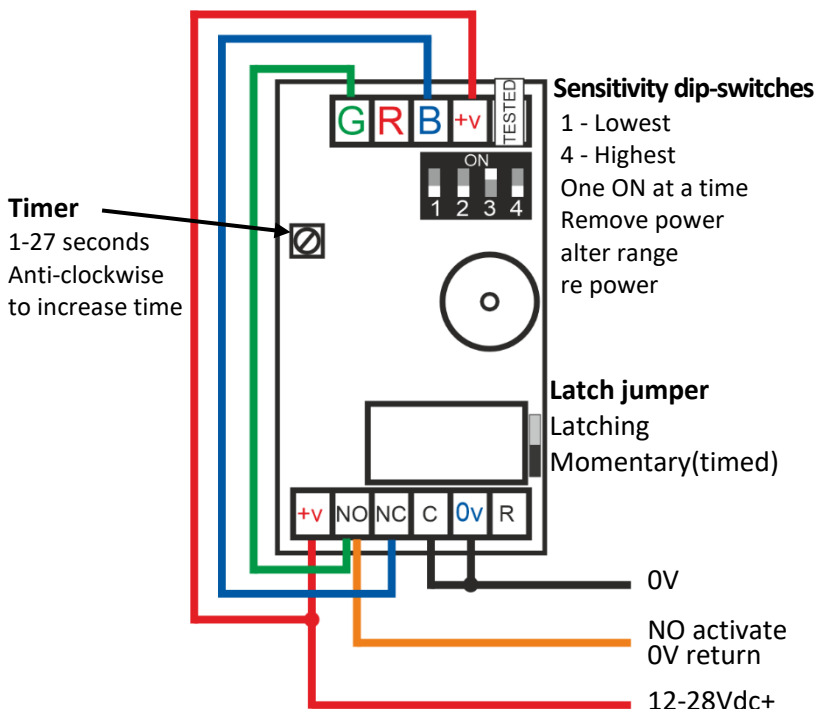

Normally open contacts. +v return (E.g. Record operators)

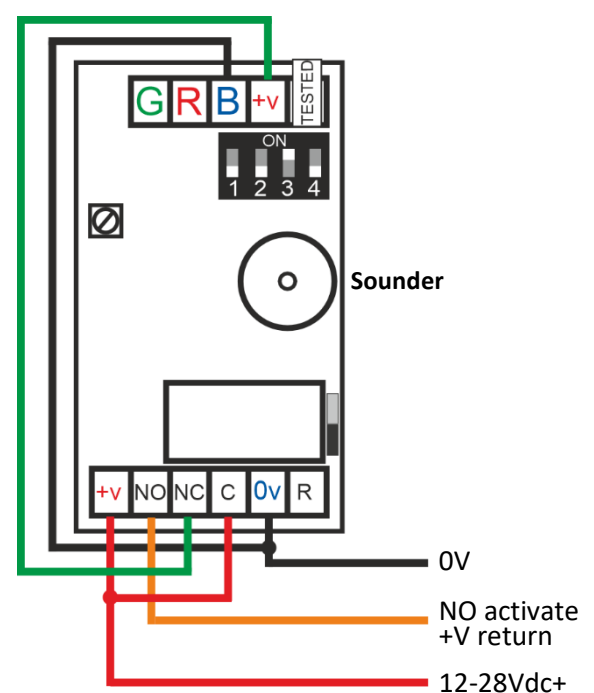

If using a square illuminated unit, connect the LED wires to the terminals marked on the large outer LED panel PCB, instead of the touch sensor PCB

Radio programming (RX-2 receiver)

Supply receiver with 12/24Vdc power. +V to 12/24V terminal, -V to GND terminal. LED will light if powered correctly

Wire relay outputs to activate terminals on the system (clean, normally open contacts)

Press and release the learn button, the learn LED will light up for 10 seconds

Within the 10 seconds operate the touch sensor

The learn LED will flash to confirm it has programmed

Note: Touch sensors program to channel 1. The RX-T receiver will be required if you need to program them to different channels.

It is also possible to program our handheld and desk mount transmitters (CFOB, FOB1-M, FOB2-M, FOB2-MS, FOB4-M, FOB4-MS, DDA1, DDA2) into this receiver using the same method. See transmitter box for more details.

Reset: To reset the receiver, press and hold the learn button for 10 seconds until the learn LED starts flashing. After this the memory will be deleted

Radio specification

868MHz

4 x AA batteries (Square)

4 x AAA batteries (SG)

Approximately 100,000 operations

Sounder & green LED on activation

Battery saving design, unit will only activate once if hand left on

Receiver specification

12/24Vdc supply

868MHz

2 channels

1A 24Vdc normally open contacts

Momentary/bi-stable selectable relays

200 code memory

Dimensions: 65 x 50 x 30 mm

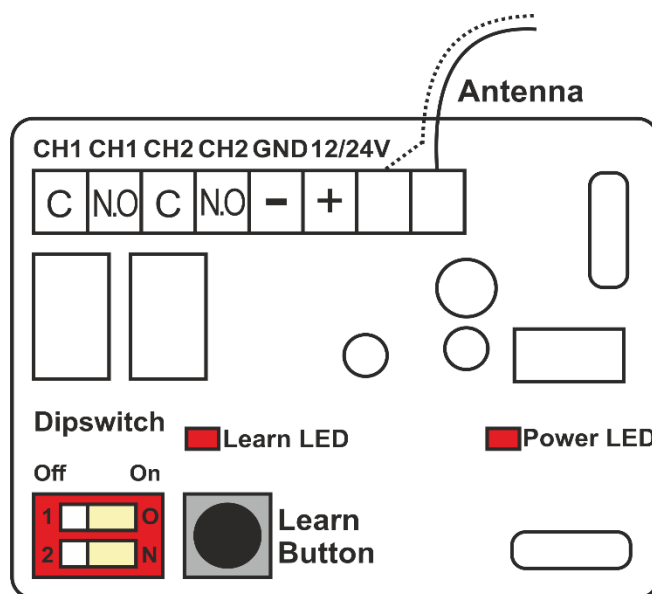

Dipswitch settings		
	ON	OFF
1	CH1 - Bi-Stable	CH1 - Momentary
2	CH2 - Bi-Stable	CH2 - Momentary



Programming video

Note:

Matching screw cover stickers are supplied as an optional feature for aesthetic purposes.

If required, they should be affixed after the unit has been installed. To affix them, simply peel off the yellow adhesive backing and stick them over the two screws. They can be easily removed with a knife for battery changes.

Spares are may also be supplied, these should be left inside the unit.