

GridScan/Pro

Installation and Operation Manual

**EN 12453
E device**



CEDES AG is certified according to ISO 9001: 2015

English	Pages	1 – 13	Original version
Deutsch	Seiten	14 – 25	
Français	Pages	26 – 37	
Italiano	Pagine	38 – 49	
Español	Páginas	50 – 61	
日本語	ページ	62 – 73	

Contents

1.	About this manual	2
1.1	Measurements	2
1.2	Related documents	2
1.3	CEDES headquarters	2
1.4	Certification Body	2
2.	Safety information	3
2.1	Non-intended use	3
3.	Symbols, safety messages	3
3.1	Safety messages categories	3
4.	Introduction	4
4.1	Features of the GridScan/Pro	4
4.2	Types - GridScan/Pro	4
4.3	Type description	4
4.4	Intended use	4
5.	Overview	5
5.1	Delivery package	5
5.2	General instructions and precautions	5
5.3	Alignment	6
6.	Application overview	6
6.1	Door blanking	7
7.	Installation	7
8.	Electrical connection	8
8.1	Outputs	8
8.2	Test input	9
9.	Timing diagram	10
10.	Start-up	10
11.	LED status description	10
12.	Troubleshooting	11
13.	Maintenance	11
14.	Disposal	11
15.	Technical data	12
16.	Dimensions	13

1. About this manual

2	This installation and operation manual in English, with metric and inches measurements is the original version .
2	The version number is printed at the bottom of each page.
2	To make sure you have the latest version, visit www.cedes.com where this manual and related documents can be downloaded.
3	1.1 Measurements
3	Measurements are, if not stated otherwise, given in mm (non-bracketed numbers) and inches (numbers in brackets).
4	1.2 Related documents
4	GridScan/Pro datasheet 001 233 en
5	1.3 CEDES headquarters
5	CEDES AG
6	Science Park
6	CH-7302 Landquart
7	Switzerland
7	1.4 Certification Body
8	TÜV NORD CERT GmbH
8	Langemarckstr. 20
9	DE-45141 Essen
10	Germany

2. Safety information

IMPORTANT READ BEFORE INSTALLATION!

The GridScan/Pro was developed and manufactured using state-of-the-art systems and technologies. However, injury and damage to the sensor can still occur.

To ensure safe conditions:

- ▶ Read all enclosed instructions and information.
- ▶ Follow the instructions given in this manual carefully.
- ▶ Observe all warnings included in the documentation and attached to the sensor.
- ▶ Do not use the sensor if it is damaged in any way.
- ▶ Keep the instruction manual on site.

The GridScan/Pro should only be installed by authorized and fully trained personnel! The installer or system integrator is fully responsible for the safe integration of the sensor. It is the sole responsibility of the planner and/or installer and/or buyer to ensure that this product is used according to all applicable standards, laws and regulations in order to ensure safe operation of the whole application.

Any alterations to the device by the buyer, installer or user may result in unsafe operating conditions. CEDES is not responsible for any liability or warranty claim that results from such manipulation.

Failure to follow instructions given in this manual and/or other documents related to the GridScan/Pro may cause customer complaints, serious call backs, damage, injury or death.

2.1 Non-intended use

The GridScan/Pro **must not** be used for:

- Protection of dangerous machine
- Equipment in explosive atmospheres
- Equipment in radioactive environments



Use only specific and approved safety devices for such applications, otherwise serious injury or death or damage to property may occur!

3. Symbols, safety messages

Symbol	Meaning
▶	Single instruction or measures in no particular order
1.	Sequenced instructions
2.	
3.	
•	List, in no order of importance
→	Reference to a chapter, illustration or table within this document
Important	Important information for the correct use of the sensor

3.1 Safety messages categories

Warning of serious health risks

WARNING
Serious health risks

Highlights critical information for the safe use of the sensor. Disregarding these warnings can result in serious injury or death.

- ▶ Follow the measures highlighted by the triangle-shaped arrows
- ▶ Consult the safety information in Chapter 2 of this manual

Caution of possible health risk

CAUTION
Possible health risks

Highlights critical information for the safe use of the sensor. Disregarding these warnings can result in injury.

- ▶ Follow the measures highlighted by the triangle-shaped arrows
- ▶ Consult the safety information in Chapter 2 of this manual

Notice of damage risk

NOTICE
Risk of damage

Disregarding these notices can lead to damage to the sensor, the door controller and/or other devices.

- ▶ Follow the measures highlighted by the triangle-shaped arrows

4. Introduction

The GridScan/Pro is a very reliable SIL 2 certified safety light curtain. It was developed and designed to safeguard all types of industrial doors such as sectional or high-speed doors. The system is ideal for door openings up to 10 m wide and can handle door closure speed of 1.6 m/s. The opening speed is up to 3 m/s. The emitter and receiver can be installed directly into the guide rail (blanking version) or to the front or the back of the door (static version). Therefore, a blanking version as well as a static version (without door blanking) are available.

The GridScan/Pro has a selectable output of Frequency Safety Signal (FSS) or Push-Pull, so one system can handle all relevant outputs. Selecting the FSS output allows operation according to EN ISO 13849-1:2015 Cat. 2 without periodic testing of the light curtain. This output is included in the TÜV certification of the GridScan/Pro.



Figure 1: Typical GridScan/Pro application environments

4.1 Features of the GridScan/Pro

- TÜV – EC Type examination certified
- SIL 2 certified
- Direct integration into the door edge due to door blanking
- Combined output with PNP/NPN (push-pull) and FSS
- Easiest alignment
- 2nd output for additional information
- Ideal for modernization projects due to FSS control unit
- Door closing speed up to 1.6 m/s
- Fulfills SIL 2 without testing if FSS output selected
- Version with communication interface available
- Cross section only 12 mm × 14.5 mm

4.2 Types - GridScan/Pro

• Standard

The standard type features door blanking and resolution, according to EN 12978:2009. This means there are different resolutions between elements along the length of the edge.

Important: The standard type is certified according to EN ISO 13849-1:2015 and EN 12978:2009 if the door is monitored over its full height up to 2.5 m (8.2 ft).

• ST type

The ST type has no door blanking feature. It can be used as a Cat. 2 safety light curtain for different applications.

Important: The ST type is certified according to EN ISO 13849-1:2015 and EN 12978:2009 if the door is monitored over its full height up to 2.5 m (8.2 ft).

4.3 Type description

GRS/Pro – aa – bbbb – cc, dd, ee, ff

aa	:	SY	System
		Tx	Emitter
		Rx	Receiver
bbbb	:	Safety length in mm	
cc	:	Number of elements	
dd	:	-	Standard type with blanking
		ST	Static type
ee	:	Information of output 1 (factory settings)	
ff	:	Information of output 2 (factory settings)	

Figure 2: Type description

Example:

- GRS/Pro SY-2500-22
GridScan/Pro system, 2500 mm safety length, 22 elements

4.4 Intended use

The GridScan/Pro is designed and approved for the mounting and use in- and outside guiding rail of industrial doors application to protect persons according to EN 12978:2009 and EN 12453:2017.

The GridScan/Pro can be used as a safety device according EN 12453:2017 as E-device and fulfills the safety levels up to SIL 2 according to EN 61508:2010 and the category 2 (cat. 2) / performance level d (PL d) according to EN ISO 13849-1:2015.

5. Overview

The emitter and receiver edges create a grid of infrared beams offering up to 2.5 m (8.2 ft) in protection height. When the infrared beams are interrupted, the output sends a signal to the connected door control unit. As soon as the detection area is clear again, the output switches to indicate that the area is "clear". The blanking system (standard versions, Chapter 4.2) is designed to mount directly into the guide rails. As the door closes, the GridScan/Pro recognizes the door as such and does not switch the output.



Figure 3: Sectional doors with door blanking



Figure 4: High-speed doors with door blanking

5.1 Delivery package

The GridScan/Pro package comprises:

- 1 × GridScan/Pro emitter edge (Tx)
- 1 × GridScan/Pro receiver edge (Rx)
- 1 × Synchronization cable 10 m (33 ft)
- 1 × Connection cable 5 m (16.5 ft)
- 1 × Installation guide

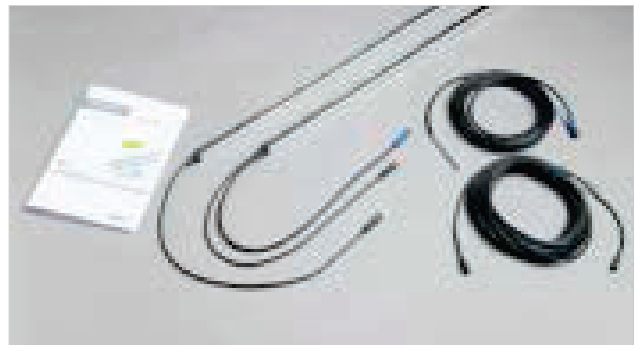
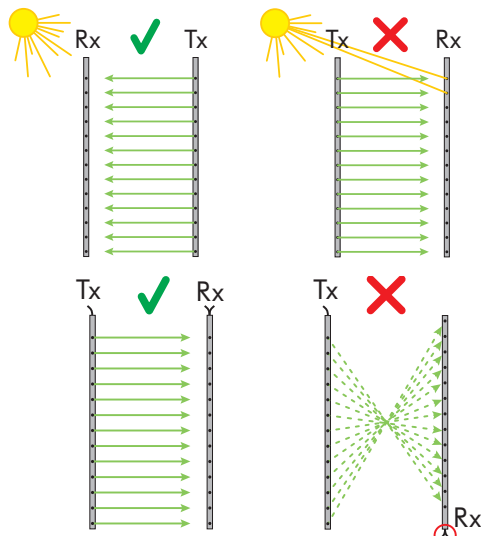

Figure 5: Typical GridScan/Pro delivery package

5.2 General instructions and precautions



- ▶ Never scratch or paint the optical lenses because they form the light path! Do not drill additional holes into the profile. Unpack the profiles just before installation in order to avoid damage.
- ▶ Do not bend or twist the edges!
- ▶ Oil can damage the cables. Contamination must be avoided at all times!
- ▶ Chemical can damage the profile and optical characteristics. Contact must be avoided at all times!



- ▶ Although the GridScan/Pro is insensitive to direct sunlight, avoid all unnecessary exposure if possible, most especially to the receiver.
- ▶ Avoid interference from blinking lights or infrared light sources such as photo cells or other light curtains.
- ▶ Do not install the GridScan/Pro in places where the emitter and receiver edges are directly exposed to light sources such as FL tubes or energy saving lamps.
- ▶ Make sure to place the connection plugs for both the emitter and receiver at the same end.

CAUTION
Damage to the eye

Although the GridScan/Pro does not emit dangerous amounts of infrared light, long exposure to intense infrared light sources can result in damage to the eyes.

- ▶ Never look directly into the active infrared emitter from a close distance.

5.3 Alignment

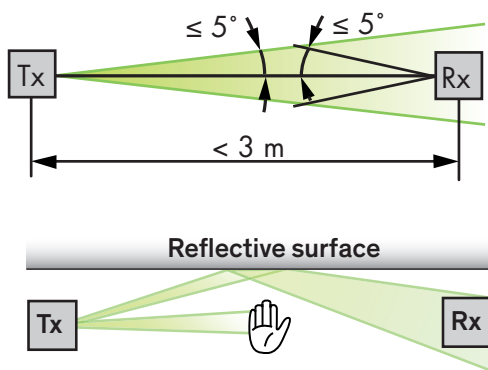

The optical axis of the emitter (Tx) and the receiver edge (Rx) need to be aligned towards each other to ensure the light curtain functions reliably.

Reflective surfaces near to or parallel to the safeguarded area can cause reflections and interfere with the GridScan/Pro's functions. Keep a reasonable distance between the sensor edges and any reflective surface.

A self calibration on each optical beam is implemented. At the power-up the ideal emitting strength will be detected and used. To reduce interruption caused of dust the system checks the emitting power and adapt a new higher or lower strength if necessary.

6. Application overview

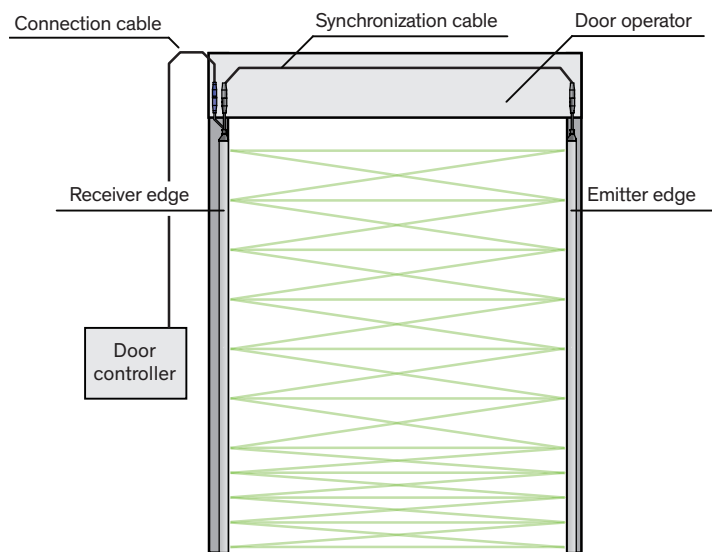

Figure 6: GridScan/Pro application (overview)

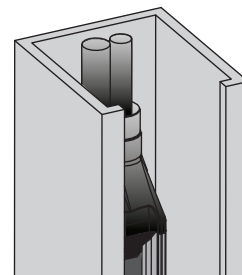

Figure 7: GridScan/Pro with door blanking (standard type)

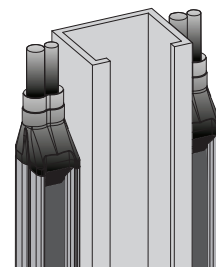

Figure 8: GridScan/Pro with static mounting (ST type)

6.1 Door blanking

The GridScan/Pro can differentiate between a light beam interruption caused by an object and a light beam interruption caused by the closing door. The GridScan/Pro does this by analyzing the different interruption patterns.

Closing door interruption pattern:

The light beam interruption of a closing door starts at the topmost beam going downwards. There are two ways to achieve blanking:



Figure 9.1 Door blanking through door edge

When the GridScan/Pro is integrated into the guide rail, the door moves directly in front of the light curtain. This means the lowest section of the door needs to be at least 30 mm in height to ensure that at least one element is completely covered. It is also essential that the door's leading edge extends the full distance between the light curtain's emitter and receiver (Figure 9.1).

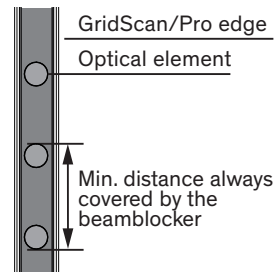

Figure 9.2 Door blanking through beam blocker

If the light curtain is located either in front of or behind the guide rail, the descending door will not interrupt the active beams. However, blanking may still be required if any part of the door (e.g. cable) interrupts the light curtain. A beam blocker can be used but it must be mounted so that at least one element is continuously covered during door closure (Figure 9.2).

7. Installation



WARNING

Electrical and mechanical hazards

Electrical shock and unexpected door movement can cause serious injury or death.

- ▶ Follow all applicable safety measures.
- ▶ Use only specific and approved tools.
- ▶ If the GridScan/Pro has to be adjusted, the main power supply must be switched off and marked as out of service.

NOTICE

Mechanical damage to the GridScan/Pro

- ▶ Do not drill additional holes into the light curtain.
- ▶ Do not overtighten the mounting screws.
- ▶ Mount the edges on a flat surface.

1. Switch off main power to the door control unit and mark clearly that this system is out of service before performing any work on the system.
2. Mount the receiver edge on one side of the door.

Important for standard types:

- ▶ Mount the receiver edge into the guiding rail next to the door control unit (Figure 7).
- ▶ In order to fulfill EN 12978:2009 the lower end of the edges have to be at the level of the door closed position.

Important for ST types:

When the GridScan/Pro is statically mounted (Figure 8) the door must not interrupt the beams (no door blanking).

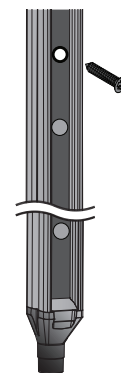
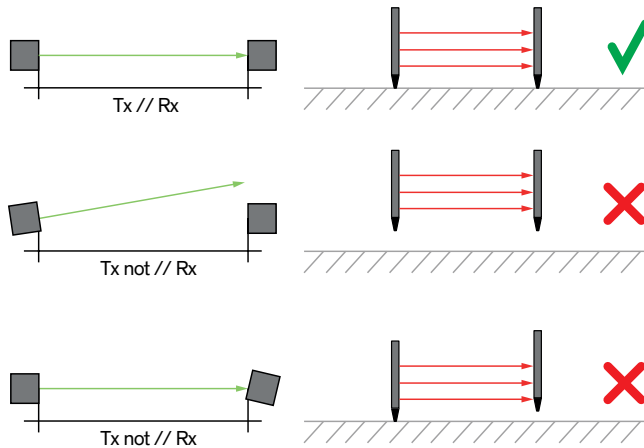

Figure 10: Front mounting

3. Mount the emitter edge across from the receiver edge. If the receiver is mounted in the guiding rail the emitter should be mounted in the guiding rail opposite the receiver.

Important: Make sure the optical elements are facing each other (Chapter 5.3).



4. Connect the emitter with the receiver edge using the synchronization cable.
5. Plug the connection cable into the blue plug on the receiver edge and connect it to the door controller (Chapter 8).

8. Electrical connection

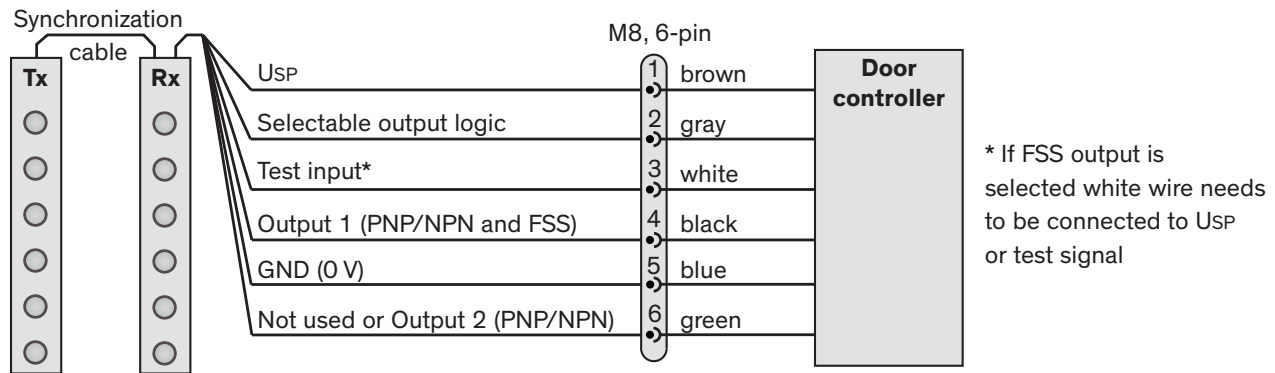

Figure 11: Connection diagram

Important: Any unconnected (not used) wire must be separated and isolated.

8.1 Outputs

When an object enters the safeguarded area (OBJECT DETECTED) the GridScan/Pro output changes after response time t_2 (Chapter 9). When the object leaves the safeguarded area (NO OBJECT) the GridScan/Pro output switches back after release time t_3 .

8.1.1 Changing the output logic

Output 1 logic is set using the gray wire. The logic will be defined by the power-up sequence. After the power-up the logic will not change until the next power-up is made. The default logic is LO (light-on) (used in the timing diagram). The output logic is LO if the gray wire is connected to GND (0 V). Connecting the gray wire to Usp (10 ... 30 VDC) changes the output logic to DO (dark-on). If the gray wire is not connected (floated), the output logic changes to the FSS signal.

Gray wire	Output 1 Logic
Connected to GND (0 V)	Push-Pull LO
Connected to Usp	Push-Pull DO
Not connected (floated)	FSS

Table 1: Output 1 logic selection table

Output selector connected to GND (0 V)



Output selector connected to USP



Output selector not connected (floated)



Figure 12: Output 1 logic

8.1.2 FSS output (Frequency Safety Signal)

The FSS is a 1 kHz safety output allowing for safeguarding according to EN ISO 13849-1:2015, without using a test signal. As long as the safeguarded area is free, the FSS output sends a 1 kHz signal. When an object enters the safeguarded area (OBJECT DETECTED), the FSS output switches to LOW/GND (0 V). When the object leaves the safeguarded area (NO OBJECT) the frequency starts again (Chapter 9).

8.1.3 Output 1 - factory settings

Output 1 is delivered in the following versions. The settings refer to the "ee" type description (see Chapter 4.3).

, ee	-	-	Output 1 switches when person/object is detected or 3 seconds after door closure (reactivates when the 11th element from bottom is uninterrupted again).
		ST type	Output 1 switches when person/object is detected.

Other options are available on request.

8.1.4 Output 2 - factory settings

Output 2 (PNP/NPN) is delivered in the following versions. The settings refer to the "ff" type description (see Chapter 4.3).

, ff	-	Standard - no Output 2
, 2Z		Output 2 switches when person/object is detected using the single-element detection method (11th element from the bottom, 490 mm).
, 2Y		Output 2 switches when person/object is detected using the single-element detection method. In this case, the element will be blanked during door blanking (11th element from the bottom, 490 mm).
, 2X		Output 2 switches immediately after door closure (reactivates when the lowest element is uninterrupted again).

Other options are available on request.

8.2 Test input

To fulfil EN ISO 13849-1:2015 the GridScan/Pro with PNP/NPN output (N type) must be tested by the door controller before each door closing cycle. The GridScan/Pro is available in a standard version with "Test active LOW".

Important: When the FSS output is used, using the test input is not necessary to achieve safeguarding according to EN ISO 13849-1:2015. In this case, the white wire has to be connected to the USP.

9. Timing diagram

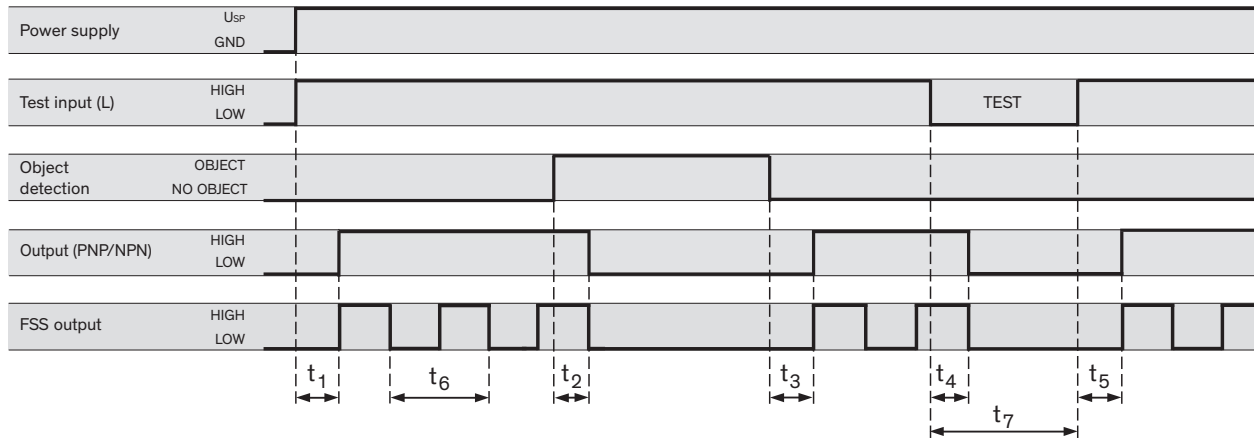

Figure 13: General timing diagram

	Time	Value [ms]
Power-up time	t ₁	max. 1,700
Response time with 22 elements	t ₂	typ. 40 max. 80
Release time	t ₃	max. 50
Test response time	t ₄	max. 80
Restart time	t ₅	max. 200
FSS sequence time	t ₆	1
Test time	t ₇	min. 100

Table 2: General timing table

	PNP / NPN
Power supply U _{sp}	10 ... 30 VDC
Power supply GND	0 V
Test input HIGH	> 10 VDC
Test input LOW	< 2 VDC
Output HIGH	> U _{sp} - 2 VDC
Output LOW	< 2 VDC
FSS output HIGH	3.4 ... 4.2 VDC
FSS Output LOW	< 1 VDC

Table 3: General value table

10. Start-up

1. Switch on mains and power-up the door control unit. The LED on the receiver edge blinks during the start-up phase.
2. Check the LED on both edges (power, status).
3. Test if the system is working correctly by letting the door open and close, interrupting the light during the opening and closing process.

11. LED status description

Receiver edge (Rx)

Green LED	Red LED	Sensor status
●	○	Light curtain free
○	●	Safeguarded area interrupted or door closed
○	⦿	Start-up (slow blinking)
○	⦿	Internal malfunction (fast blinking)
○	○	No power or edge is defective (see Chapter 12)

Table 4: LED status description receiver edge

● = LED on ○ = LED off ⦿ = LED blinking

Emitter edge (Tx)

Green LED	Sensor status
●	Power OK
○	No power or edge is defective (see Chapter 12)

Table 5: LED status description emitter edge

12. Troubleshooting

Tx LED Green	Rx LED Green	Rx LED Red	Action
LED off	LED off	LED off	<ul style="list-style-type: none"> ▶ Check electrical connections. ▶ Check supply voltage of the door controller.
LED off	LED off	LED red	<ul style="list-style-type: none"> ▶ Check the connection of the synchronization cable.
LED green	LED green	LED off	<ul style="list-style-type: none"> ▶ Make sure the sensor edges are not mounted close to any shiny or reflective surface. ▶ Restart the system.
LED off/on (flickering green)	LED off	LED off/on (flickering red)	<ul style="list-style-type: none"> ▶ Check power supply. ▶ Check connections.
LED green	LED off	LED off/on (slow blinking red)	<ul style="list-style-type: none"> ▶ Make sure the safeguarded area is clear of interruption. ▶ Check the alignment of the light curtain. ▶ Clean elements.
LED green	LED on/off (flickering green)	LED off/on (flickering red)	<ul style="list-style-type: none"> ▶ Make sure the safeguarded area is clear of interruption. ▶ Clean the elements. ▶ Make sure that the cables and edges are located away from sources of electromagnetic interference. ▶ Ensure that the emitter and receiver are correctly aligned and remain so during door closure (e.g. that vibrations do not cause edges to become misaligned). ▶ Restart the system.
LED green	LED off	LED red	<ul style="list-style-type: none"> ▶ Make sure the safeguarded area is clear of interruption. ▶ Reopen door completely. ▶ Clean the elements. ▶ Check the alignment of the light curtain. ▶ Check that the test input is connected to the test output signal of the door control unit and that the signal level and logic (HIGH/LOW) are correct. If the test input is not used, connect it permanently to Usp. ▶ Measure the Usp voltage. ▶ Restart the system.
LED off	LED off	LED off/on (slow blinking red)	<ul style="list-style-type: none"> ▶ Check the connection of the synchronization cable.
LED green	LED off	LED off/on (red, fast blinking, 5 Hz)	<p>Internal error occurred</p> <ul style="list-style-type: none"> ▶ Restart the system. ▶ Replace Rx edge.

Important: Whenever a parameter is changed, the system must be restarted.

If a problem persists, please contact your local CEDES representative. Visit www.cedes.com for contact data.

13. Maintenance

Although the GridScan/Pro does not need regular maintenance, a periodic functional check is strongly recommended:

- ▶ Make sure the optical elements are clear of dirt and dust. If necessary, clean the front surface with a soft towel.
- ▶ Make sure the edges are securely fastened.
- ▶ Check the mounting position, cable routing and connection of the sensor.

NOTICE

Damage to the optical elements

- ▶ Never use any solvents, cleaners or mechanically abrasive towels or high-pressure water to clean the sensor.
- ▶ Avoid scratching the optical elements while cleaning.

14. Disposal

The GridScan/Pro should only be replaced if a similar protection device is installed. Disposal should be done using the most up-to-date recycling technology according to local regulations and laws. There are no harmful materials used in the design and manufacture of the sensor. Traces of such dangerous materials may be found in the electronic components but not in quantities that are harmful.

15. Technical data

Optical

Operating range	1...10 m (3 ... 33 ft)
Number of elements	20, 22, 36, 42
Max. protection height	2,500 mm (98.5 in)
Max. ambient light	100,000 Lux

Mechanical

Cross section	12 mm × 14.5 mm (0.47 in × 0.57 in)
Housing material	Natural anodized aluminum
Enclosure rating	IP68 (Cable: IP67)
Temperature range	−40 °C ... +60 °C (−40 °F ... +140 °F)

Electrical

Supply voltage U_{sp}	10 ... 30 VDC
Current consumption with 22 elements at 24 VDC	50 mA
Output	PNP/NPN (push-pull) and FSS
Output load	100 mA, 100 nF
Typ. response time with 22 elements	40 ms
Max. response time with 22 elements	80 ms
HW Watch dog	200 ms
Max. door closing speed	1.6 m/s
Max. door opening speed	> 3 m/s
Status LED Rx:	
- Object detected	red
- No object detected	green
Power LED Tx:	
Power ok	green

Connection cable and electrical connection

Synchronization cable

Length	10 m (33 ft)
Connection	Screwable M8, 4 pin
Diameter	Ø 3.5 mm (Ø 0.14 in)
Material	PVC, black
Plug color	Black
Wires	AWG26
• brown	U_{sp}
• blue	GND (0 V)
• black	Communication
• white	Not used

Connection cable

Length	5 m (16.5 ft)
Connection	Screwable M8, 4 pin
Diameter	Ø 4.2 mm (Ø 0.17 in)
Material	PVC, black
Plug color	Blue
Wires	AWG26
• brown	U_{sp}
• blue	GND (0 V)
• black	Output 1 (PNP/NPN and FSS)
• white	Test input
• gray	Selectable output logic
• green	Not used or Output 2 (PNP/NPN)

General

EMC emission	EN 61000-6-3:2007 EN 12015:2014
EMC immunity	EN 61000-6-2:2005 EN 12016:2013
Vibration	IEC 60068-2-6:2007
Shock	IEC 60068-2-27:2008
RoHS	2011/65/EU
Certificates	CE, TÜV
Safety categories	EN ISO 13849-1:2015, Cat. 2, PL D EN 61508:2010, SIL 2 EN 12978:2009 EN 12453:2017 E device
Applicable standards	UL 325:2012

16. Dimensions

All dimensions in mm (for 22 elements)

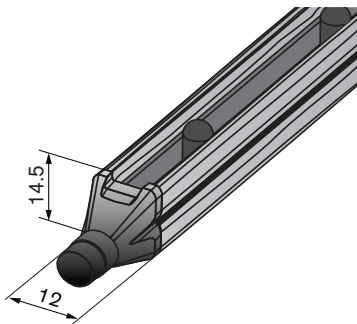
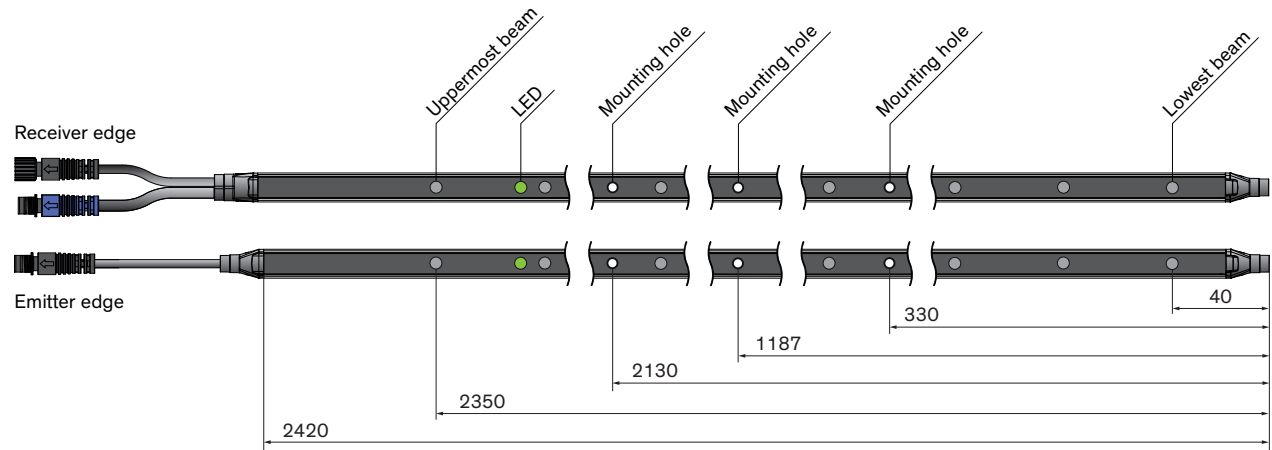

US measurements

All dimensions in inches (for 22 elements)

