

PRESENCE MODE WITH ADDED RADAR PROTECTION.

EL00W-RAD

Introducing EL00W-RAD e-LOOP Wired system that has been designed for high operational sites.

The quick and easy solution to fitting wired induction loops. Just one simple line trace to cut or cover the wire with a cable cover for a complete surface mount option, without the need for any site work.

Fitting options are surface mount and flush mount for the presence mode loop, or surface mount, flush mount, or completely concealed for the exit mode.



Surface Mount



Flush Mount

Specifications

Part number: EL00W-RAD.

Load capacity: 10T.

Input voltage: 12-24VDC.

Current: Standby 20mA, Active 30mA.

Relay connections: NC/COM/NO.

Relay contact ratings: 1A.

Cable: 6 core 4.1 mm diameter 10 metres long.

Features

- Magnetic field and Radar detection.
- Fully potted for 100% water protection.
- Wireless connection is still available for connection of diagnostic tools as per all the e-Loop range.
- High security 128 bit encryption.
- Designed for above-ground and in-ground flush mounting.
- IP69.



Wired Commercial e-Loop PRESENCE MODE

EL00W-RAD



This wired Vehicle Detection System uses magnetometer sensors to detect the presence of oncoming vehicles. These detections are sent via a relay to the gate or other device that requires activation. The sensors are installed on the surface of entry or exit passages using concrete fixing bolts can be core bored into concrete or asphalt.

Functions / Features

Lower power consumption 3-axis magnetometer for vehicle detection

- 8 Hz sampling rate
- Auto-calibration
- Exit/Entry detection mode

Fast and simple installation

- Quick non-permanent installation

Relay Outputs

- COM, N/O & N/C
- Supply voltage 12-24VDC

The Radar sensors can detect vehicles that are stopped above the e-loop. The added radar utilises two-way radio communication protocol for reliable operation. Once the magnetometer sensor detects an oncoming vehicle, the transceiver relay will be latched and confirmation will be sent back to the e-loop. If the magnetic field drops below the set threshold, the radar will check if a vehicle is present. If no vehicle is detected, an unlatch command is sent to the relay, and the transceiver will send a confirmation to the e-loop. If the confirmation is missed, multiple attempts will be made to ensure A safe operation. Radar settings can be adjusted using the e-diagnostics remote. Settings that can be changed include; Dead zone, sensor distance, sensitivity, magnetic field release level, confirmation mode.

DISCLAIMER: UNITS WITH THE PRESENCE FEATURE IS NOT TO BE USED AS A SOLE SAFETY DEVICE & SHOULD BE USED IN CONJUNCTION WITH STANDARD GATE SAFETY PRACTICES.

Radio Specifications

Frequency	433.39 MHz
Modulation	FSK
Bitrate	9.6 kbps
Bandwidth	250 kHz
Antenna Type	PCB
Nominal Output Power	10 dBm
Receive Sensitivity	-126.2 dBm
Security	128-Bit AES Encryption
Spurious Emissions	<ul style="list-style-type: none"> • 30 - 1000 MHz: < -56 dBm • 1 - 12.75 GHz: < -44 dBm • 1.8 - 1.9 GHz: < -56 dBm • 5.15 - 5.3 GHz: < -51 dBm

Compliance

Safety	Tested to CE Approval
EMC	<p>FSK Tested to: EN 301 489-1 V2.2.3 "Electro Magnetic Compatibility (EMC) standard for radio equipment and services; Part 1: Common technical requirements; Harmonised Standard for Electro Magnetic Compatibility" Including: a)_Emissions to EN 55032 "Electromagnetic compatibility of multimedia equipment". b)_Transmitter and receiver test to EN 300 220-1 V3.1.1 'Short Range Devices (SRD) operating in the frequency range 25MHz. to 1000MHz; Part 1: Technical Characteristics and methods of measurement." c)_Immunity Tests to EN 301 489-1</p>

Power, Physical and Environment

Power	12-24VDC Input
Dimensions	120*120*20mm (70mm inside)
Weight	500g
Environment	<ul style="list-style-type: none"> • Designed for above ground and in-ground mounting. • IP69 ingress Protection
Operating Temp	-40° to 100° C
Standby Power	15mA
Activation Power	30mA

Detection Specifications

Activation Time	300ms
-----------------	-------

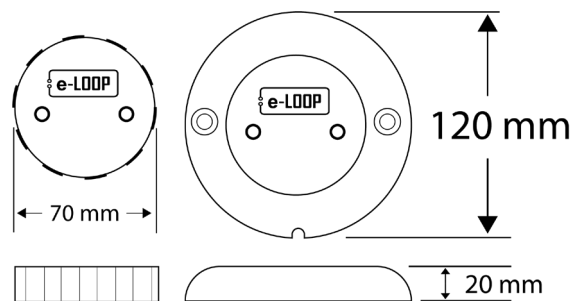

Magnetometer Detection Areas

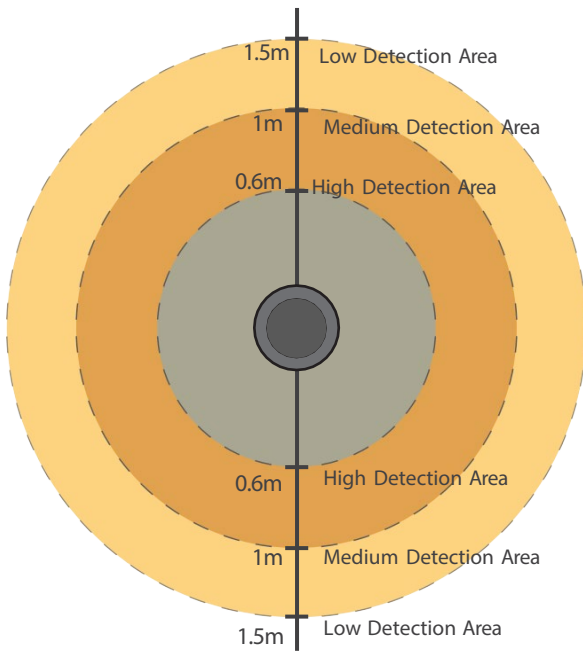

Varying magnetic field detection zones. The grey area depicts a 0.6m high sensitivity detection area surrounding the loop, suitable for the majority of vehicles. The dark colour area depicts a 1m medium sensitivity detection area surrounding the e-loop, suitable for most vehicles. The light colour area depicts a 1.5m low sensitivity detection area surrounding the e-loop, which is only suitable for some vehicles.

Radar Read Distances

Radar detection range. Spanning from a 60° FOV from the e-loop, these are the range zones. The grey area depicts the dead zone, in which objects cannot be detected. The Minimum read distance is 0.6m. The default read distance is 1.3m, and the Maximum read distance spans up to 2m.

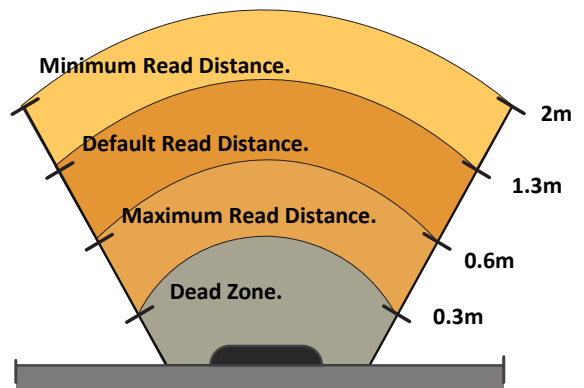

Flush Mount

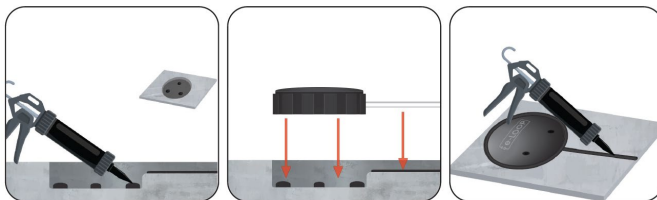

Surface Mount

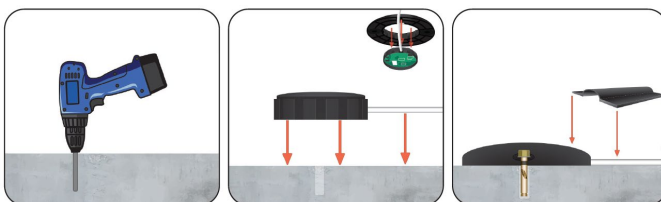

The e-LOOP must be installed in a place that is always visible. Do not place the e-LOOP in a hollow or in an area where snow or water can accumulate. Keep e-LOOP in the centre of the lane so that it passes directly under vehicles. Screw e-LOOP to the surface using only the concrete screws supplied or rubberised adhesive. Do not drill the screws at an angle.